

## **Pile Foundations Under Uplift Loads: An Overview\***

**Prabhakar Jagannath Pise†**

### **INTRODUCTION**

#### **General**

**M**y involvement in Geotechnical Engineering has been from the beginning of my career at Indian Institute of Technology Kharagpur, since 1964, when I joined the premier Institute as a faculty member. My Ph.D. dissertation was on, "Pile Foundations under Vertical and Lateral Loads" – An Experimental Laboratory Investigation. This was the beginning to proceed further to carry out research in the broad area of "Pile Foundations under Different Loading Systems" - Analytical and Experimental Studies. A number of research scholars, M.Tech and B.Tech students who have worked with me carried out their research/projects in the area of "Pile Foundations". Most of the research findings are in the published form in the Journals/Conferences in India and abroad. I have been keenly interested in the experimental work from the beginning of my career. Considering the overall contributions during the last 15 years by me and co-workers, I have chosen the topic, "Pile Foundations under Uplift Loads - An Overview" for the lecture/presentation.

#### ***Scope of Presentation***

1. Present state of knowledge on soil-pile-uplift load as critically reviewed from the Literature
2. Contributions by the Author and his co-workers at IIT Kharagpur in details

---

\* 26th Annual Lecture delivered at IGC-2003.

† Former Professor, Indian Institute of Technology Kharagpur, India. Presently AICTE Emeritus Fellow, Government College of Engineering, Pune – 411005, Maharashtra, India.

3. Presentation of the literature in concise form
4. Identification of the parameters affecting the uplift behaviour of piles and pile groups
5. Research problems with shortcomings are addressed for future work.

## **Pile Foundations**

A shallow foundation is usually provided when the soil at a shallow depth i.e. up to the significant depth has adequate capacity to support the load of the superstructure. However, in situations where the top soil is either loose or soft or of swelling type, the depth of foundation has to be increased till a suitable stratum is met in order to transmit the load safely. In such situations pile foundations are the obvious choice. Piles are usually used in groups to provide foundations for structures. The pile groups may be subjected to vertical compressive or uplift loads, horizontal loads or combination of vertical and horizontal loads.

## **Pile-Soil Interaction Phenomenon**

Pile-soil interaction problem is very complicated. The phenomenon is a function of pile material, its surface characteristics, length, diameter, soil-pile friction angle, geometry of group, methods of installation and end conditions, soil characteristics like consistency, compactness, stratification, consolidation, sensitivity, drainage conditions, dissipation of excess pore pressures and shear parameters, location of water table and type of loading. Extensive theoretical and experimental investigations are available on the behaviour of piles and pile groups subjected to axial, inclined or lateral compressive loads. They relate to load carrying capacity of the piles/pile groups, load-displacement response, buckling etc. Consequently the design and analysis of piles under these loading conditions can be done with greater assurance and economy under normal operating conditions.

## **PILE FOUNDATIONS UNDER UPLIFT LOADS**

Foundations of some structures like transmission towers, mooring systems for ocean surface or submerged platforms, tall chimneys, jetty structures etc. are subjected to uplift loads. Grillage footings, rock anchors, concrete steel cased piles, and concrete cylindrical piles are extensively used in such cases depending on in-situ conditions. Cased or uncased cylindrical piles are generally used where caving, high water table or other causes make it difficult and costly for constructing other types of foundations. Large inclined uplift loads act on the foundations of retaining walls, anchors for bulkheads, bridge abutments, piers, anchorage for guyed structures and

offshore structures, which are generally supported on piles. However, when the foundation is required to carry large inclined loads, inclined or batter piles along with vertical piles are used.

The design of pile foundation under compressive load is, in general, based on the requirements that complete collapse of the pile group or of the supporting structure should not occur under the most adverse conditions and that the displacements at working loads should not be so excessive so as to impair the proper functioning of the foundation or damage the superstructure. The allowable displacements depend on the importance of the structure and the practice followed in the particular country or their Professional Societies or Institutions. Thus for structures in which displacements may not be critical, the design is governed by the ultimate resistance of the pile or pile groups and the allowable load is often determined by applying a suitable factor of safety to the computed load.

## General Analysis Under Uplift Loads

The limiting frictional approach is the universal approach followed to evaluate the uplift resistance of piles, which is practically similar to the analysis of piles to compressive loads. The analysis is based on the formation of the failure surface under the action of uplift load or empirical correlations based on the experimental investigations. The uplift capacity theories of piles have been mostly extended from the analysis of horizontal plate anchors under uplift load and development of failure surfaces starting from the edges of the anchor. Pile is considered as a cylindrical shaft and the failure surfaces may be similar to those developed for the anchors. Different failure surfaces assumed/considered for the horizontal plate anchors and the equations developed to predict the uplift capacity of the plate anchors by many scientists are reviewed and presented by (Dickin and Leung, 1990; Ramesh Babu, 1998). The analysis and theories pertaining to horizontal plate anchors have not been described/discussed here to restrict the scope of the present review to piles only.

## Analysis of Single Pile

### *Piles in Clayey Soil*

For uniform pile in clay, the ultimate uplift resistance,  $Q_u$ , is taken as,

$$Q_u = c_a A_s + W_p \quad (1)$$

where  $c_a$  = average adhesion along pile shaft

$W_p$  = Weight of pile

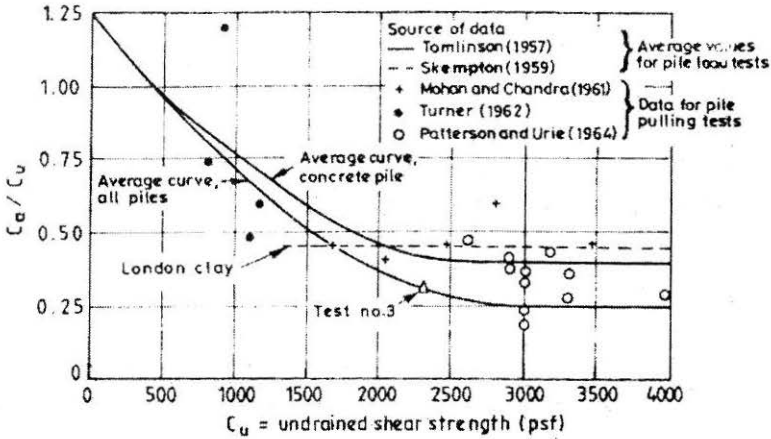

FIGURE 1 : Relationship Between  $c_a/c_u$  and Undrained Shear Strength for Pulling Tests (Sowa, 1970)

$A_s$  = surface area of the embedded pile

$c_u$  = undrained cohesion

A summary of some of the available results is given by Sowa (1970), who has found that the values of  $c_a/c_u$  agree reasonably well with the values for piles subjected to downward loading. Figure 1 shows the quantitative and qualitative relationship between  $c_a/c_u$  and undrained shear strength for pulling tests. The values of  $c_a/c_u$  are more for soft clays and much less for stiffer clays.

### *Piles in Sandy Soil*

In sandy soils the gross uplift capacity  $Q_u$  of a vertical pile is assumed to depend on the skin resistance developed between the pile shaft and the soil. Generally a limiting friction approach is used and the gross uplift capacity of a pile of diameter,  $d$ , embedment length,  $L$ , is expressed as,

$$\begin{aligned} Q_u &= p_{av} \pi d L \\ &= (1/2 K_s \tan \delta \gamma L) \pi d L \end{aligned} \quad (2)$$

where

$K_s$  = coefficient of earth pressure

$p_{av}$  = average skin friction =  $(1/2 K_s \tan \delta \gamma L)$

$\delta$  = soil-pile friction angle

$\gamma$  = effective unit weight of soil

From the generalised approach of estimating the ultimate uplift capacity of a single pile it can be realised that length, diameter, type of soil, pile material and its surface characteristics, method of installation and the coefficient of earth pressure  $K_s$  are the important factors on which in reality the development of skin friction or adhesion along the shaft will depend.

### *Piles with Enlarged Base*

Additional uplift resistance may be obtained by under reaming or enlarging the base of the pile, and in such cases, the pile shaft may have little or no influence on the uplift capacity. Traditional methods of design assume the resistance of the enlarged base to be the weight of a cone of earth mass having sides that rise either vertically or at  $30^\circ$  from the vertical. Neither of these methods is reliable in practice. However, the  $30^\circ$  cone method is usually conservative at shallow depths but considerably overestimate uplift capacity at large depths.

Meyerhof and Adams (1968) have developed an approximate approach based on observations made in laboratory model tests. They suggest that the short term uplift capacity of a pile in clay (under undrained condition) is given by the lesser of

- (a) The shear resistance of a vertical cylinder above the base, multiplied by a factor  $k$ , plus the weight of soil and pile,  $W_f$ , above the base.
- (b) The uplift capacity of the base plus  $W_f$ , that is,

$$Q_u = c_u N_u \pi (d_b^2 - d^2) / 4 + W_f \quad (3)$$

where

$d_b$  = diameter of the base

$d$  = diameter of the shaft

$N_u$  = uplift coefficient  $\approx N_c$  for downward load

They suggested the following values of  $k$ :

Soft clays	$k = 1 - 1.25$
Medium clays	$k = 0.7$
Stiff clays	$k = 0.5$
Stiff fissured clays	$k = 0.$

It has been found that negative pore pressures may occur in clays during uplift, particularly with shallow embedment depths. The uplift capacity

under sustained loading may therefore be less than the short-term or undrained capacity, because the clay tends to soften with time as the negative pore pressures dissipate. The long-term uplift capacity can be estimated from the theory for a material with both friction and cohesion, using the drained parameters  $\phi_d$  and  $c_d$  of the clay.

After the foregoing general discussion, for convenience the "Overview on the Available Literature", as far as possible, has been presented below in chronological order. It has been restricted for vertical piles and pile groups under axial uplift/pullout loads

## REVIEW OF LITERATURE

### Ireland (1957)

He reported uplift test results of five step tapered Raymond piles, cast-in-situ, depths varying from 4.75 m to 5.29 m in fine sand of marine origin. Water table was near the ground surface. He indicated that the values of  $K_s$  may be more than the coefficient of Rankine's passive earth pressure coefficient  $K_p$  as used in Eqn.2.

### Begemann (1965)

If static-cone-penetration tests are used as a basis for estimating uplift skin resistance, Begemann suggests that the calculated skin resistance for downward loading be adjusted by a reduction factor dependent on the soil and pile type. He also suggests reduced values of skin resistance be used if the uplift load is oscillating.

### Downs and Chieurzzi (1966)

They reported results of uplift tests on cased and uncased cylindrical piles depths, varying from 3 m to 4.5 m and diameters between 460 mm to 488 mm in soft moist silty to clayey fine sand. In analyzing the results, they used the expression for net uplift capacity as,

$$P_u = \pi d \frac{L}{2} (K L \tan \phi + 2c)$$

where  $K$  = coefficient of lateral earth pressure.

Their results reflected effect of type of casing and method of backfilling on uplift capacity.

### Meyerhof and Adams (1968)

Meyerhof and Adams (1968) have developed an approximate generalised theory of uplift resistance of foundations embedded in soil. The theory is based on the observations and test data. It has been proposed for a strip or continuous footing and has been modified for circular and rectangular footings and also to account for group action. As this analysis is widely used it has been briefly described here.

Figure 2 shows the theoretical model of the failure surface and forces acting on it for shallow and great depth for a strip footing. The notations used in the Fig.2 are self-explanatory and are not defined here.

#### Strip Footing

At the ultimate uplift load  $Q_u$  a soil mass having an approximately truncated pyramidal shape is lifted up and, for shallow depths, the failure surface reaches the ground surface. Making suitable assumptions and logical approximations, the following equations are derived.

#### Shallow Depth

$$Q_u = 2cD + \gamma D^2 K_{pv} + W_f \tag{4}$$

where  $K_{pv} = K_p \tan \delta$ , and taken as equal to,

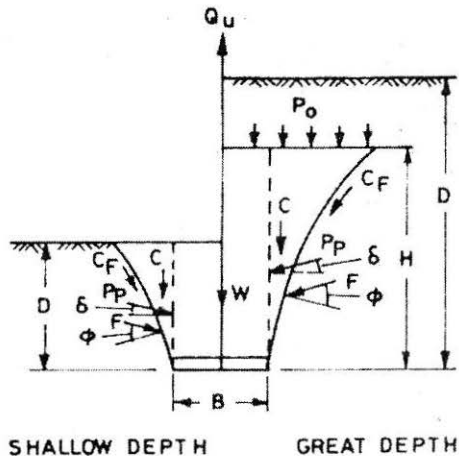

FIGURE 2 : Failure of Soil Above a Strip Footing Under Uplift Load (Meyerhof and Adams, 1968)

$$K_{pv} = K_u \tan \phi \text{ for convenience.}$$

where  $K_u$  = nominal uplift coefficient of earth pressure on vertical plane through footing edge.

From the test results on model footings in sand, the average angle of the failure surface with the vertical varies between about  $\phi/3$  and  $2\phi/3$ . For an average value of about  $\phi/2$ , trial calculations have shown that  $\delta$  is approximately  $2\phi/3$ . From the corresponding passive earth pressure coefficients  $K_p$  based on curved failure surfaces, the vertical component  $K_{pv}$  governing the uplift resistance has been evaluated.

### Great Depth

$$Q_u = 2cH + \gamma(2D - H)HK_u \tan \phi + W_f \quad (5)$$

The magnitude of  $H$  can be estimated only by determining from the observed extent of the failure surface (Table 1).

The upper limit of the uplift resistance is given by the sum of bearing capacity of the footing and skin friction on the anchor shaft

$$Q_u = B(cN_c + \gamma DN_q) + A_s f_s + W_f \quad (6)$$

where  $A_s$  = surface area of the shaft

$f_s$  = average unit skin friction of soil on shaft

$N_c, N_q$  = bearing capacity factors as for downward loading.

The analysis for strip footing has been extended to circular footings by determining the shearing resistance from cohesion and friction and passive earth pressure,  $P_p$ , inclined at  $\delta$  on a vertical cylindrical surface through the edge of the footing edge. For a soil with both cohesion and friction, the following expressions are obtained by them for the ultimate load capacity,  $Q_u$ , of a circular base:

TABLE 1

Friction Angle $\phi$ (degrees)	20	25	30	35	40	45	48
Depth H/B	2.5	3.0	4.4	5.0	7.0	9.0	11.0



**Circular Footing***Shallow Depths* ( $L < d_b$ )

$$Q_u = \pi c d_b L + s \pi \gamma d_b L^2 K_u \tan \phi / 2 + W_f \quad (7)$$

*Great Depths* ( $L > H$ )

$$Q_u = \pi c d_b H + s \pi \gamma d_b (2L - H) H K_u \tan \phi / 2 + W_f \quad (8)$$

where

 $d_b$  = diameter of the base of the footing $c$  = unit cohesion $s$  = shape factor governing the passive earth pressure on a convex cylindrical wall=  $1 + mL/d_b$ , with a maximum value of  $1 + mH/d_b$  $m$  = coefficient depending on  $\phi$  (Table 2) $H$  = limiting height of failure surface above base $W_f$  = weight of soil lifted above base and foundation $K_u$  = nominal uplift coefficient of earth pressure on vertical plane through footing edge.

The values of  $K_u$  are found to vary from about 0.7 to nearly unity. For granular materials it has been found that  $K_u$  is relatively constant for a wide range of  $\phi$  and may be taken approximately 0.9 - 0.95 for  $\phi$  values between  $25^\circ$  and  $40^\circ$  for strip footings. Test results on model circular footings have shown that for sands the average angle of failure surface with the vertical varies between  $\phi/4$  and  $\phi/2$ . For an average value of about  $\phi/3$  the angle  $\delta$  is approximately  $2\phi/3$  and the corresponding values of shape factors were estimated from approximate earth pressure theories based on plane failure surfaces.

TABLE 2

Friction Angle $\phi$ (degrees)	20	25	30	35	40	45	48
Coefficient $m$	0.05	0.1	0.15	0.25	0.35	0.5	0.6
Max Factor $s$	1.12	1.30	1.60	2.25	3.45	5.50	7.60

The upper limit of the uplift capacity is the sum of the net bearing capacity of the base, the side adhesion of the shaft, and the weight of footing and soil lifted above base, that is,

$$Q_u = \pi/4(d_b^2 - d^2)(cN_c + \sigma'_{vb} N_q) + A_s f_s + W_f \quad (9)$$

where  $f_s$  = ultimate shaft shear resistance

$\sigma'_{vb}$  = effective vertical stress at level of footing base

### **Rectangular Footing**

An approximate analysis for the ultimate uplift load of a rectangular footing of width  $B$  and length  $L$  can be obtained as for downward loads by assuming that the earth pressure along the perimeter of the two end portions of length  $B/2$  is governed by the shape factor  $s$  for circular footings, while the passive earth pressure along the central portion of length  $(L - B)$  is the same as for a strip footing.

#### *At Shallow Depth*

$$Q_u = 2cD(B+L) + \gamma D^2(2sB+L-B)K_u \tan \phi + W_f \quad (10)$$

#### *At Great Depth*

$$Q_u = 2cH(B+L) + \gamma(2D-H)H(2sB+L-B)K_u \tan \phi + W_f \quad (11)$$

With an upper limit as for the bearing capacity under downward loading.

For square footing,  $B = L$  in the above expressions.

### **Footing Groups**

The ultimate uplift load of a footing group is the smaller value of either the sum of the uplift loads of the individual footings or the uplift load of an equivalent pier foundation consisting of the footings and enclosed soil mass. While the sum of the uplift loads of the individual footings can readily be determined from the expressions given for single footings, the uplift load of the equivalent pier foundation can be determined by the method suggested for rectangular footings. Thus for a group of circular footings it is assumed that the passive earth pressure along the curved portions of the perimeter of the group is governed by the shape factor  $s$  and the passive earth pressure along the straight portions is the

same as for strip footing. Meyerhof and Adams referred to the tests carried by Wiseman on groups of model footings in sand. From the test results it was observed that for close spacings the failure surface was curved at the outside.

For example, a rectangular group at shallow depth has approximately an ultimate uplift resistance of  $Q_u$  as

$$Q_u = 2cD[a + b + (\pi/2)B] + \gamma D^2[a + b + s(\pi/2)B]K_u \tan \phi + W_g \quad (12)$$

with a maximum of

$$Q_u = \text{number of footings} \times Q_u \text{ of individual footings} \quad (13)$$

where  $a$  and  $b$  = distance between centers of corner footings on length and width, respectively, of group

$W_g$  = weight of footing group and weight of soil mass enclosed.

They suggest that the values of  $N_c$  and  $N_q$  for downward load can be used in this context, but theoretically this is incorrect, and somewhat lower values may be appropriate to upward loading. They suggested that the ultimate uplift capacity should be taken as the lesser value given by Eqns.12 and 13.

Meyerhof and Adams reported that for a given density of sand the uplift coefficients of the groups increased roughly linearly with the spacing of the footings or shafts and the efficiencies increased as the depth of embedment became smaller. The efficiencies decreased as the number of footings or shafts increased and as the density of sand increased. Comparison between theory and test results showed better agreement at great depths than at shallow depths where the estimates were quite conservative. They also extended the study for clayey soil and found that the drained or long term capacity was appreciably less than the undrained capacity. The reduction with time was attributed to the dissipation of negative pore water pressure, which allowed softening of soil.

### Sowa (1970)

Analyzing field test results of cast-in-situ cylindrical piles in sandy soils using Eqn.2 Sowa exhibited that in one case,  $K_s$ , is considerably less

than  $K_0$  and  $K_a$ , where  $K_0$  is the coefficient of earth pressure at rest and  $K_a$  is Rankine's active earth pressure coefficient. In another case  $K_s$  is approximately equal to  $K_0$ . Analyzing the test results on concrete piles in sandy deposits, reported by Adams and Hayes (1967) and Downs and Chieurzzi (1966) he concluded that very large values in excess of  $K_0$  for  $K_s$  might occur. He further inferred that it is very difficult to select a value of  $K_s$  even for preliminary design.

### Vesic (1970)

Vesic considered the cavity-expansion model. On the basis of test results on a driven instrumented pile in a predominant sandy deposit he indicated that the ultimate skin friction on the piles is same both in tension and compression. He concluded that beyond a critical value of  $10d$  in very loose sand and about  $20d$  in very dense sand the average unit frictional resistance  $f$  results into a fixed value  $f_f$  which is a function of relative density of sand,  $D_r$ , and mode of placement of pile. He suggested the following empirical relation to evaluate the limiting skin friction in tons per square feet

For driven piles

$$f_f = (0.08)10 \exp(1.5) D_r^4$$

For bored piles and piers in dry sand

$$f_f = (0.025)10 \exp(1.5) D_r^4$$

### Tran-Vo-Nhiem (1971)

Tran-Vo-Nhiem developed an equation for uplift capacity of piles on the assumption that the passive pressures act on the side of the pile. He considered that the passive pressures on the side of the pile are proportional to the square of the depth. By integrating the vertical component of these passive pressures on the shaft of the pile he developed the following expression

$$Q_u = A_s (\gamma L M_{\phi R} + C M_{CR})$$

where

$A_s$  = embedded surface area of the pile

$M_{\phi R}$ ,  $M_{CR}$  = dimensionless coefficients depending on  $\phi$  and  $d/L$  ratios

He concluded that the analysis gives reliable predictions for piles embedded in sufficiently compacted medium

### **Meyerhof (1973)**

He introduced an uplift coefficient  $K_u$  in place of  $K_s$  in the Eqn.2. For a particular angle of shearing resistance  $\phi$  of the soil the value of  $K_u$  is shown to increase with increase in slenderness ratio  $L/d$ , up to a maximum value and thereafter it remains constant. It is designated as limiting uplift coefficient. However, the limiting coefficient is shown to increase with increase in angle of shearing resistance.

### **McClelland (1974)**

He demonstrated the effects of installation on uplift capacity of piles by field tests on identical steel pipe piles of diameter 508 mm installed to a penetration of 14.63 m in uniform beach sand by four different techniques. The driven pile exhibited net uplift capacity, which is 1.4 times that of a pile installed by jetting with external return flow. He concluded that the ultimate shaft resistance depends on the methods of driving/installation.

### **Das and Seeley (1975)**

The ultimate capacity of vertical piles under axial pull in loose granular soil is investigated. A wooden rough model pile 25.4 mm diameter and 610 mm length embedded in silica sand having  $\phi = 31^\circ$  was tested. The possible variation of unit uplift friction with embedment depth is analyzed. It is concluded that the unit uplift skin friction for piles is approximately linear with depth up to a critical embedment ratio, beyond which it reaches a limiting value. The final skin friction is attained at a depth of about 10 - 12 pile diameters. However, this may not be true for all granular soils.

### **Das, Seeley and Smith (1976)**

They investigated the variation of uplift capacity of pile groups considering various parameters like shape, size and spacing. The tests are limited to one  $L/d$  ratio embedded in sand of one compaction. Rough wooden model piles 305 mm long and 12.7 mm in diameter having  $L/d = 24$  were used. Group sizes of 1,  $1 \times 2$ ,  $1 \times 3$ ,  $1 \times 4$ ,  $2 \times 2$ ,  $2 \times 3$ ,  $3 \times 3$  were fabricated. Spacing varied from  $2d$ ,  $4d$ ,  $6d$ , and  $8d$ . They found that for all groups in general the efficiency increases with increase in spacing up to 4 - 6 diameters and then it attains roughly a value of 100%. Isolation spacing generally occurred between 4 - 6 pile diameters. The group efficiency decreased with number of piles in the group. Fig.3 shows the typical results of group efficiency with spacing presented by them.

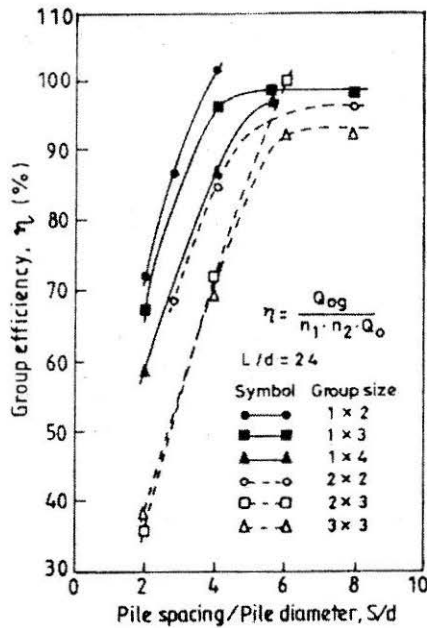

FIGURE 3 : Plot of Group Efficiency vs. Spacing (in Pile Diameter)  
(Das, Seeley and Smith, 1976)

### Sulaiman and Coyle (1976)

The study describes correlations achieved for piles subjected to uplift loads by comparing computed load versus pile movement curves with the actual behaviour of the field piles. Apparatus consisted of a triaxial shear device, modified to accept a 25.4 mm diameter steel pipe pile, centered within the soil sample without tip resistance. Results in terms of skin friction/lateral pressure i.e. chamber pressure, versus pile movement are recorded. Degree of saturation varied between 75% - 89% without effect on skin friction values. Normal drainage was allowed throughout the test.

### Awad and Ayoub (1976)

Awad and Ayoub (1976) used Vierendeel's static bearing capacity formula based on earth pressure theory to arrive at a theoretical expression for the net uplift capacity of a circular rough pile as

$$Q_u = 1/2 \gamma \mu d L^2 \tan^2 (\pi/4 + \phi/2)$$

where  $Q_n$  = net uplift capacity of a pile  
 $\mu$  = coefficient of friction

Suggested values of  $\mu$  are 0.33 for cast-in-situ concrete piles and 0.25 for all other piles.

### Sharma, Jain and Chandra Prakash (1978)

They have suggested evaluating the ultimate uplift capacity of under-reamed piles by computing skin friction along the shaft and bearing pressure on the annular area of the under-reamed bulb using the following expression.

$$P_u = \pi/2 dk \gamma \tan \delta (d_1^2 + L^2 + d_n^2) + \pi/4 (B_1^2 - d^2) (1/2 n \gamma B_1 N_\gamma + \gamma N_\gamma + N_q) \quad (14)$$

where  $d$  = diameter of the pile shaft  
 $d_1$  = depth of centre of the first under-reamed bulb  
 $d_n$  = depth of the centre of the last under-reamed bulb  
 $B_1$  = diameter of under-reamed bulb  
 $n$  = number of under-reamed bulbs  
 $k$  = coefficient of earth pressure, usually taken as 1.75 for sandy soils  
 $N_\gamma, N_q$  = bearing capacity factors depending on  $\phi$ .  $\delta$  may be taken equal to  $\phi$ .

The factor  $N_q$  which is given by Vesic (1963) should be reduced by 50%. It is based on the fact that in case of bored piles the point resistance has been found to be half to one third of the resistance offered by driven piles.

For single under-reamed pile the above expression reduces to the form

$$P_u = \pi/2 dk \gamma \tan \delta L^2 + \pi/4 (B_1 - d^2) (1/2 B_1 N_\gamma + \gamma N_q) \quad (15)$$

### Ismael and Klym (1979)

They reported full-scale uplift test results on instrumented cylindrical pier, 1.07 m in diameter and 6.4 m deep in compact fine to medium brown sand with some silt and trace of clay. The piers were installed by slurry

displacement method. The water table was located near ground surface. Analyzing the results, they suggested the use of same value in tension and compression of  $K_u$  as suggested by Adams (1975). These values vary from 0.5 to 2.0 for very loose to very dense condition of sand.

### **Kulhawy, Kozera, and Withiam (1979)**

They, on the basis of test results on large-scale straight shafted cast-in-place model drilled shafts in sand found that available theoretical models do not predict the observed capacities. However, their test results indicated that at failure,  $K_s = K_a$  in loose sand and  $K_s = (K_p)^{1/2}$  in dense sand.

### **Chandra Prakash (1980)**

He modified the expression given by Sharma et al. (1978) as,

$$P_u = \pi/2 d K_{ul} \gamma \tan \delta L^2 + \pi/4 (B_1^2 - d^2) (\gamma N_q d_1) \quad (16)$$

where  $K_{ul}$  = limiting uplift coefficient given by Meyerhof (1973)  
 $N_q$  = bearing capacity factor reduced to 1/3 of the value given by Vesic (1963)

He has also reported field tests on isolated and group of 3.5 m long single underreamed piles of 300 mm diameter with underreamed diameter of 750 mm under uplift loading. Groups of two and three piles of variable spacing have also been tested in silty sand. The average value of  $\phi$  and unit weight of soil were  $30^\circ$  and 1.6 gm/cc respectively. He concluded that ultimate uplift capacity of isolated pile from load-displacement curve can be taken corresponding to 25 mm displacement. The group efficiency is approximately 1.0 and increases marginally with increase in spacing.

### **Das and Seeley (1981)**

Model test results on the ultimate uplift capacity of pipe piles in saturated clay are presented by them. A steel pipe 660 mm long, having an outside diameter 38.1 mm was used as model pile in saturated clay having  $c_u = 18.01$  and  $30.5 \text{ kN/m}^2$ . Corresponding moist unit weights of  $18.38$  and  $18.53 \text{ kN/m}^3$ .  $L/d$  ratios have been 4, 8, 12 and 16. Tentative equations for the variation of  $\alpha = c_a/c_u$  with the undrained shear strength of clay have been developed. For a given undrained shear strength of clay, the net pull out load and the corresponding vertical deflection of piles can be expressed by a non-dimensional equation. The equation is independent of the embedment ratio of piles. Fig.4 shows the variation of ' $\alpha$ ' with  $c_u$  for pipe piles.



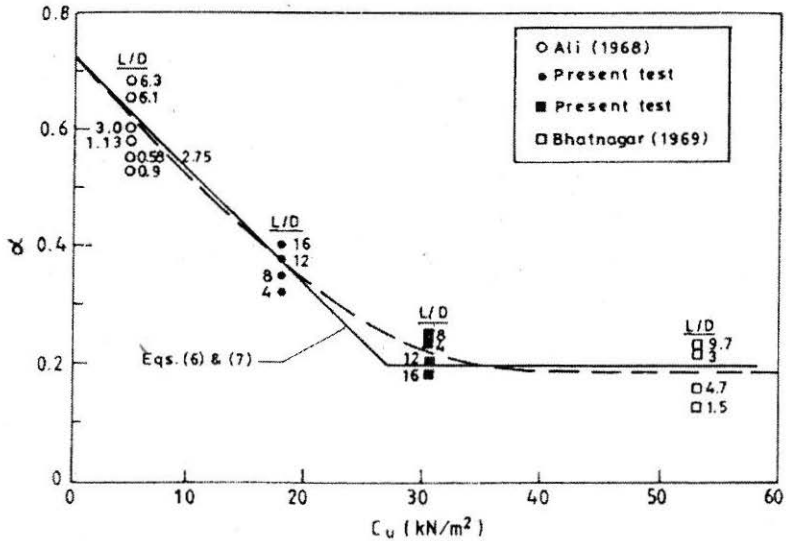

FIGURE 4 : Variation of  $\alpha$  with  $c_u$  for Pipe Piles (Das and Seeley, 1981)

### O'Neill, Hawkins and Mahar (1982)

They describe the phenomenological and analytical study of axial load transfer in a full-sized group of nine 273 mm diameter steel-pipe piles embedded 13 m in a layered over-consolidated clay. Uplift tests were conducted on six piles at the conclusion of the group and sub-group testing under compression. These piles exhibited a more nonlinear load-movement behaviour in uplift than in compression, probably due to the release of residual load. Peak side resistance in uplift was approximately equal to that in compression, although the distribution was different.

### Poorooshasb and Parameswaran (1982)

They analysed vertical uplift behaviour of a single rigid pile/pier embedded in a frozen sandy soil. The stress-strain response is idealized to be linear. It is assumed that when a rigid cylindrical pile is subjected to vertical uplift forces, the deformation of the soil around the pile shaft can be idealized as shearing of concentric cylinders. The butt movement can be obtained in a closed form expression, which is a function of pile radius, pile length, vertical load and the elastic modulus of sand. The analysis is applicable to relatively shallow piles embedded in moderately to heavily overconsolidated clays or to bored piles embedded in sensitive clays.

### Chaudhuri and Symons (1983)

They reported test results on piles of various diameters, depths, and pile surfaces embedded in medium and dense sand. The variation of skin friction along the shaft was found to be of parabolic shape with the maximum value attained nearly at 70% - 80% of the depth. The maximum value of skin friction increases with depth of embedment and it reaches a constant value at a critical depth of embedment. They indicated that the critical depth is nearly 30 times the diameter,  $d$ , of a pile in dense sand and  $11d$  in medium dense sand. For rough piles in medium dense sand it is  $15d$ . They concluded that Meyerhof's (1973) analysis is capable of reasonably estimating the uplift capacity of piles in medium dense sand. However, for rough or smooth piles in dense sand it was in significant error. Even the extreme assumption of  $K_s = K_p$  yielded conservative results. High experimental values of uplift capacity were attributed to the possibility of failure plane passing through the soil mass instead of coinciding with pile-soil interfacial plane as it is generally assumed.

### Das (1983)

Das, Seeley and Pfeifle (1977) presented some laboratory model test results for the ultimate uplift capacity of rough rigid piles in sand. Wooden pile 610 mm long and 25.4 mm in diameter, having  $L/d = 4$  to 24, were embedded in sand,  $\phi$  varying from 31 to 40.5°, compaction loose to dense condition and  $\delta/\phi = 0.4$  to 1.0. It is concluded that the unit skin friction during uplift at the soil-pile interface increases linearly with depth up to a critical depth and beyond it, it remains approximately constant. The critical embedment ratio increases with relative density of compaction. A tentative procedure for estimation of gross uplift capacity has been proposed. The method involves the soil-pile interaction parameters like, length, diameter,  $\phi$ ,  $\delta$ , uplift coefficient,  $K_u$ , and critical embedment ratio. They used the variation of uplift coefficient with angle of shearing resistance as given by Meyerhof (1973). They suggested that more laboratory and field tests are needed to test the accuracy and applicability of the procedure.

The net ultimate uplift capacity  $Q_{un}$  is expressed as,

$$Q_{un} = 1/2 p \gamma' L_{cr}^2 K_u \tan \delta + p \gamma' L_{cr} K_u \tan(L - L_{cr}) \quad (17)$$

where

$K_u$  = uplift coefficient

$L$  = length of embedment

$p$  = perimeter of pile

$\gamma'$  = effective unit weight of soil

$L_{cr}$  = critical depth

$D_r$  = relative density of sand

Based on the experimental results the critical embedment depth ratio was expressed as,

$$(L/d)_{critical} = 0.156 D_r + 3.58, \text{ for } D_r < 70\%, \text{ and}$$

$$(L/d)_{critical} = 14.15, \text{ for } D_r > 70\%$$

Figure 5 shows the variation of unit skin friction with 'L/D' and Fig.6

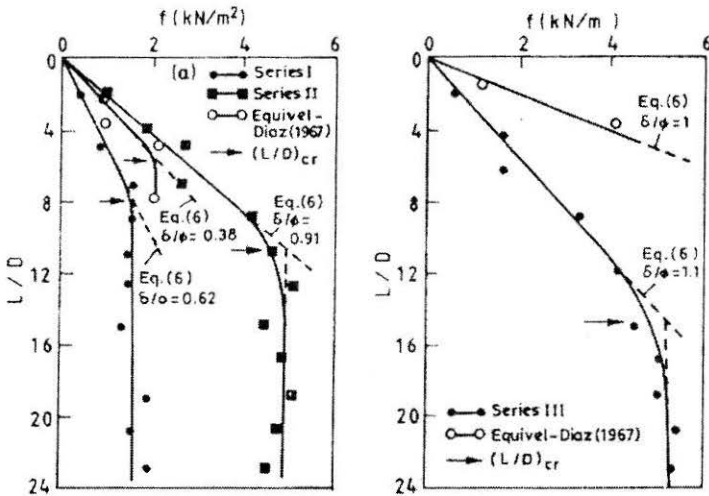

FIGURE 5 : Variation of Unit Skin Friction with L/D (Das, 1983)

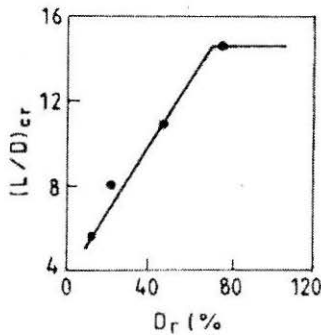

FIGURE 6 : Variation of  $(L/D)_{cr}$  with Relative Density of Compaction (Das, 1983)

shows the variation of  $(L/D)_{cr}$  with relative density of compaction.

### Levacher and Sieffert (1984)

The results of a laboratory investigation of the influences of dynamical driving methods and relative density on the behaviour of piles in tension are presented. The study includes 31 bored piles, 12 driven piles, and 5 vibro driving, pulling tests in dry sand. Steel model pile of 35 mm OD, and 900 mm embedment depth was used in the testing program. The different driving methods used are high frequency vibro-driving and driving methods. Some piles are also bored in sand. Clean, poorly graded sand at a placement density  $16.5 \text{ kN/m}^3$ , angle of shearing resistance,  $\phi = 36^\circ$  and moisture content of 4% was used as foundation medium. Experimental results show that the placement methods have a significant influence on the ultimate pulling resistance. A placement method coefficient is deduced from the tests. The ultimate resistance is attained at, displacement / d (dia.) = 0.05 - 0.11 for bored piles, 0.07 - 0.14 for driven piles, and 0.08 - 0.11 for vibro-driving piles. It is indicated that average ratio of ultimate uplift resistance of driven pile to the statically driven pile is 0.5 and that for vibro-driven pile it is 0.67. According to them, the implication of size effects are not very important.

### Das and Azim (1985)

Model tests are carried out on group of piles embedded in clay under axial uplift load. Piles were having the  $L/d$  ratio of 12 and 15. The group efficiency varied with embedment ratio, number of piles in the group and spacing of piles. Model steel piles of 25.4 mm diameter and length 457 mm in groups  $1 \times 1$ ,  $2 \times 1$ ,  $3 \times 1$ ,  $2 \times 2$ , and  $3 \times 2$  and variable spacing were

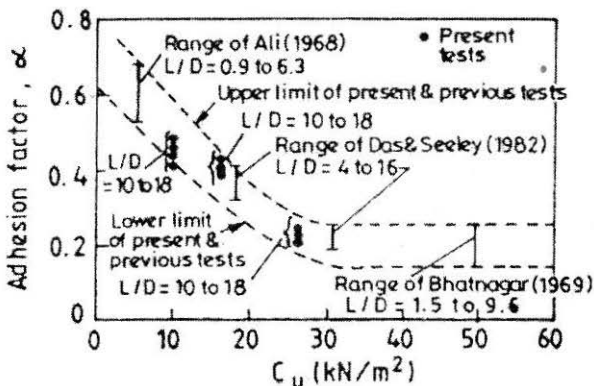

FIGURE 7 : Plot of Adhesion Factor vs.  $L/D$  (Das and Azim, 1985)

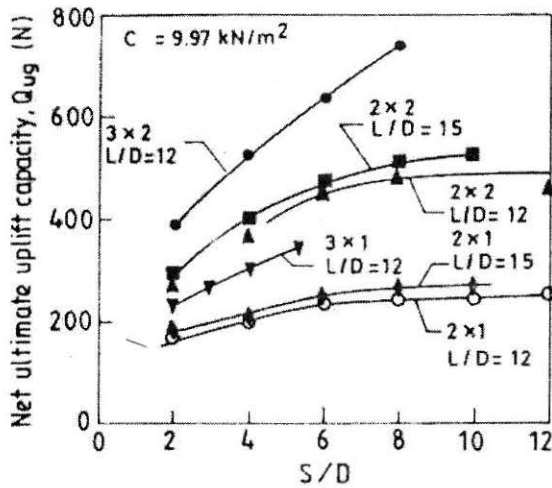

FIGURE 8 : Variation of  $Q_{ug}$  against  $S/D$  (Das and Azim, 1985)

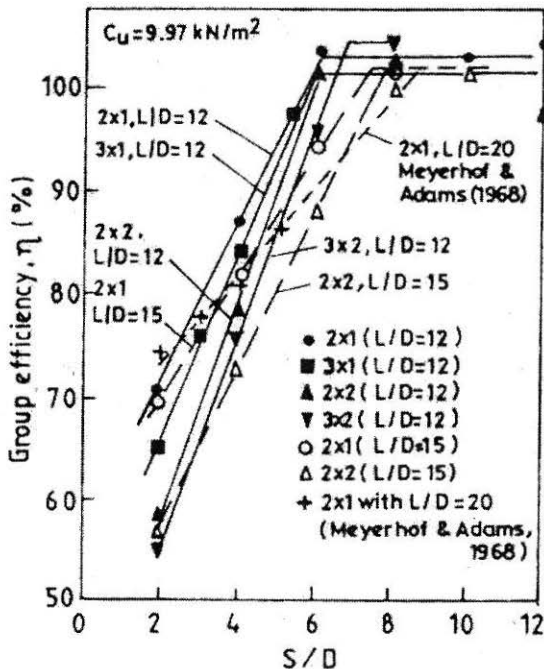

FIGURE 9 : Variation of Group Efficiency with  $S/D$  for Various Pile Group Configurations (Das and Azim, 1985)

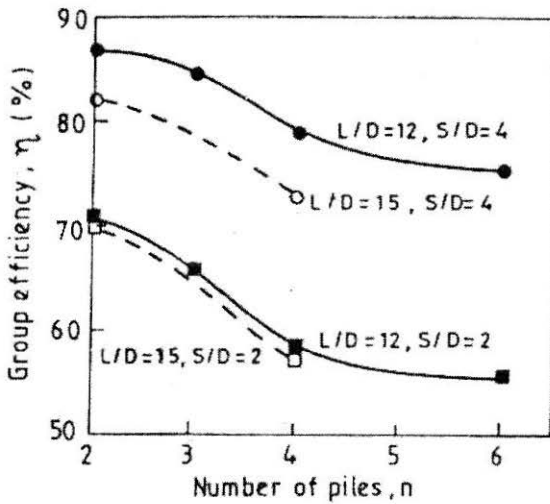

FIGURE 10 : Variation of Group Efficiency with No. of Piles in the Group and S/D (Das and Azim, 1985)

tested. The average values of  $c_u$  were 9.97 - 26.2 kN/m<sup>2</sup>. The variation of adhesion factor obtained falls in the general range of values obtained by previous investigators. For identical condition, the group efficiency increases linearly with spacing and decreases with the increase of number of piles in the group and also the embedment ratio. It reaches a value of about 100% at a spacing of about 6 - 7 times the diameter of the pile. Figure 7 depicts adhesion factor values. The variation of  $Q_{ug}$  and group efficiency with S/D is shown through Figs.8 to 10.

### Subba Rao and Venkatesh (1985)

They presented the laboratory studies on the uplift behaviour of short piles in uniform sands. Smooth and rough steel piles 12.7 mm in diameter and 320 mm in length and having  $L/d = 10, 15$  and  $20$ , in two uniform sands were used in the investigation. The frictional angle determined from drained triaxial test ranged from  $36 - 40^\circ$  for dry sands. The piles were tested under uplift as well as under compressive loading. Tests were conducted for dry and submerged conditions of soil. The uplift capacity was found to increase with  $L/d$  ratio, pile roughness, soil density and particle size. Pile movements of about 5% of pile diameter in loose sands and about 10% of pile diameter in dense sands were found to be necessary to mobilise the uplift capacity. These values are much more than 3% to 6% required for shaft loads during push-in tests. The unit skin friction during pull-out tests are significantly less than during push-in tests, especially in case of rough

piles for which it is as much as 80% less. Submergence resulted in reduction of uplift capacity in all cases. Earth pressure coefficients, however, reduced only in case of piles in dense sand and remained almost unaffected for piles in loose sands. In loose sands, earth pressure coefficient  $K$  is generally lower than Meyerhof's  $K_u$  values and in submerged dense sands the  $K$  values are in fair agreement with Meyerhof's  $K_u$  values.

**Kulhawy (1985)**

Kulhawy presented a general analysis/design model for the drained uplift capacity of drilled shaft foundations. This model evolved from extensive research to define the failure mechanism and establish the controlling parameters. In principle the uplift capacity of shaft was given by

$$Q_u = W + Q_{tu} + Q_{su}$$

$$Q_u = W + Q_{tu} + \int_{\text{surface}} \tau(z) dz$$

- where
- $Q_u$  = uplift capacity
  - $W$  = foundation weight
  - $Q_{tu}$  = tip resistance
  - $Q_{su}$  = side resistance
  - $t$  = shearing resistance along a general shear surface.

The forces acting on the shaft are shown in Fig.11. He reported that Kulhawy et al. (1983) had shown that shafts had failed principally along the

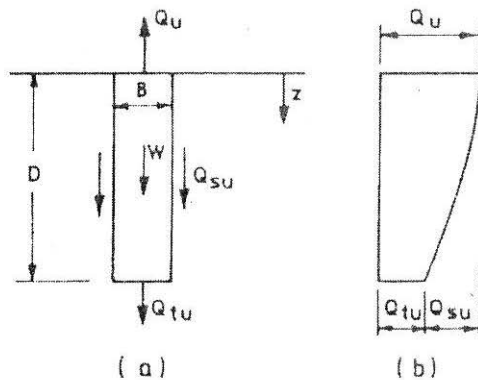

FIGURE 11 : Shaft in Uplift (Kulhawy, 1985)

soil shaft interface leading to an overall cylindrical shear. The corresponding load transfer increased from  $Q_{tu}$  at tip to  $Q_u$  at top and tip was studied by Stewart and Kulhawy (1981). Considering all factors governing side resistance e.g. angle of wall friction, operative coefficient of horizontal soil stress etc., the following equation could be obtained.

$$Q_{su} = K/K_o = \int_0^D P(z)\sigma'_v(z)K_o(z)\tan\{\phi'(z)\delta'/\phi'\}dz \quad (18)$$

where

$P$  = foundation perimeter

$\sigma'_v$  = vertical effective stress

$K$  = operative coefficient of horizontal stress

$\phi'$  = effective angle of shearing resistance

$\delta'$  = effective friction angle for soil shaft interface.

The values for concrete are  $\delta'/\phi' = 1$  and  $K/K_o = 2/3$  to 1. Tip resistance commonly in uplift was to be considered to be zero, which might be conservative. From 17 load test data measured and predicted uplift capacities were compared. The agreement was found to be very good and yielded 1 to 1 perfect predictions. A linear regression of the data was obtained with a correlation coefficient of 0.961.

### Ismael and Al-Sanand (1986)

They examined the uplift capacity of bored piles in dense calcareous soils by field tests at three sites in Kuwait. The nine test piles were 0.5 m diameter and extended to a depth of 15 m below the ground surface. The mobilized skin friction and the coefficient of lateral earth pressure were determined and compared with values obtained in noncalcareous sand. Test results were compared with empirical correlations relating skin friction to the standard penetration test results. They concluded that bored piles developed substantial skin friction in dense weakly cemented calcareous sand soils. The skin friction increased with depth for shallow depth range. The coefficient of lateral earth pressure in uplift varied between 1 and 1.2. For the piles, where failure reached, the average value of the coefficient was 1.05. Failure of bored tension piles was usually reached at an upward deflection of 5% - 10% of the pile diameter. The higher value was associated with relatively deeper piles.

### Chattopadhyay and Pise (1986)

They proposed the theoretical analysis and also carried out laboratory experimental investigation on piles under different pulling load conditions.



However, the analysis and investigation pertaining to the axial uplift loading is described here (Chattopadhyay, 1986; Chattopadhyay and Pise, 1986).

*Theoretical Analysis*

A generalised theory to evaluate uplift resistance of a circular vertical pile embedded in sand is proposed. The failure surface is assumed curved and passing through the surrounding soil mass. The lateral horizontal extent of the failure surface is dependent on the angle of shearing resistance  $\phi$  of the surrounding soil, soil-pile friction angle,  $\delta$ , and slenderness ratio  $\lambda = L/d$ .

*Analytical Model*

A vertical pile of diameter  $d$  and length  $L$  is assumed to be embedded in a soil mass as shown in Fig.12. During uplift of a pile, an axisymmetric solid body of revolution of soil along with pile is assumed to move up along the resulting surface. The movement is resisted by the mobilized shear strength of the soil along the failure surface and the weight of the soil and the pile. In the limiting equilibrium condition, ultimate capacity of the pile is attained. Following assumptions are made:

1. The shape and extent of the failure surface depend on the slenderness ratio  $\lambda$ , angle of shearing resistance  $\phi$  of the soil, and soil-pile friction angle  $\delta$ . For a particular slenderness ratio the lateral horizontal extent of the failure surface from the axis of the pile is maximum for  $\delta = \phi$ ,

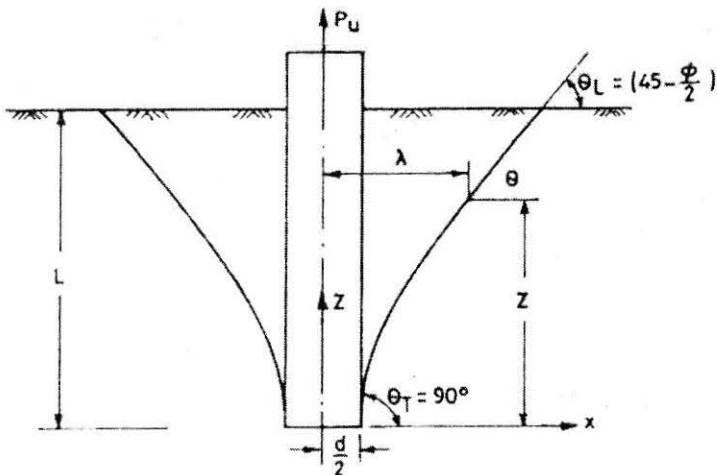

FIGURE 12 : Pile and Failure Surface (Chattopadhyay and Pise, 1986)

and gradually decreases with the decrease in the value of  $\delta$ . Further, with increasing slenderness ratio, it increases at a rate such that when it approaches infinity, it attains a limiting value at ground surface. For  $\delta = 0$ , the failure surface coincides with the interfacial plane between the pile and soil.

2. For piles with soil-pile friction angle  $\delta \geq 0$ , under ultimate uplift force,  $P_u$ , the resulting failure surface initiates tangentially to the pile surface at the tip of the pile and moves through the surrounding soil.
3. For  $\delta > 0$ , the inclination of the failure surface with the horizontal at the ground surface approaches  $(45^\circ - \phi/2)$ .

With the preceding assumptions, the slope of the failure surface at any height  $Z$  above the pile tip, in Fig.12, has been identified as

$$dZ/dx = \tan(45^\circ - \phi/2)L/Z \exp\beta(1 - Z/L) \quad (19)$$

where  $\beta = \lambda(50^\circ - \phi)/2\delta$

The expression has been arrived at on the assumption that the maximum value of  $\phi$  for practical purposes will be  $50^\circ$ . The Eqn.19 satisfies the boundary conditions also.

Integrating with proper boundary conditions and simplifying, equation given below, for the extent of the failure surface is arrived at

$$\begin{aligned} \frac{x}{d} = \frac{1}{2} + \left\{ \frac{2\delta}{(50^\circ - \phi)} \right\}^2 \frac{\exp\left\{-\lambda(50^\circ - \phi)\frac{\delta}{2}\right\}}{\left\{ \lambda \tan\left(45^\circ - \frac{\phi}{2}\right) \right\}} \\ + \left\{ \frac{2\delta}{(50^\circ - \phi)} \right\} \tan\left(45^\circ - \frac{\phi}{2}\right) \frac{\exp\{-\lambda(50^\circ - \phi)\}}{\left\{ 2\delta\left(1 - \frac{Z}{L}\right) \right\}} \left\{ \frac{Z}{L} - \frac{2\delta}{(50^\circ - \phi)} \right\} \end{aligned} \quad \dots (20)$$

#### *Ultimate Uplift Capacity*

With the pile and the proposed failure surface shown in Fig.12, it is assumed that in the limiting equilibrium condition, ultimate capacity of the

pile is attained when the mobilized shear strength along the failure surface and the weights of the body of the soil and pile balance the applied forces. A circular disc wedge of thickness  $Z$  at a height  $Z$  above tip is considered. Forces acting on the wedge are shown in Fig.13.

For evaluating the mobilized shear resistance  $\Delta T$  along the failure surface of length  $\Delta L$ , it is assumed that  $\Delta T = \Delta R \tan \phi$ , in which  $\Delta R$  is the normal force acting on the failure surface of the wedge. Further the lateral coefficient of lateral earth pressure within the wedge is taken as  $(1 - \sin \phi) \tan \delta / \tan \phi$ .

Considering the vertical equilibrium of the circular disc wedge in the limit, and further extending it to the entire failure surface, making suitable approximations, and integrating, the expression for the gross uplift capacity of the pile  $P_u$  is arrived as

$$P_u = A \gamma \pi d L^2 \tag{21}$$

where  $A$  = gross uplift capacity factor

$P_{un}$ , the net uplift capacity is expressed as

$$P_{un} = A_1 \gamma \pi d L^2 \tag{22}$$

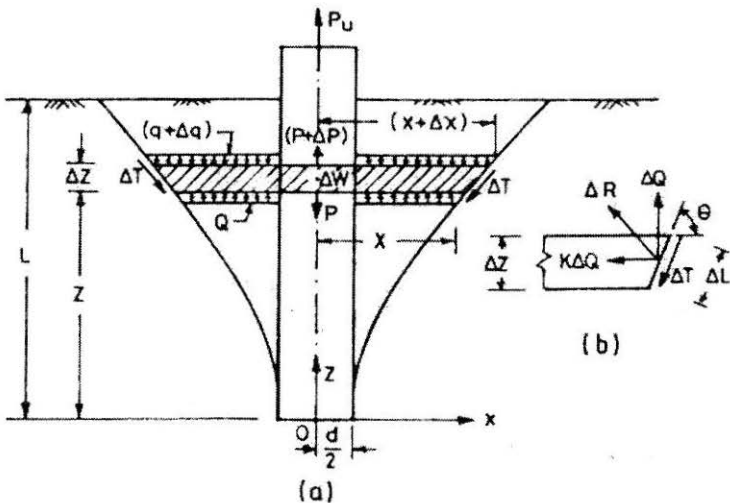

FIGURE 13 : Free Body Diagram of Circular Disc Wedge (Chattopadhyay and Pise, 1986)

where  $A_1$  = net uplift capacity factor

Average skin friction,  $P_{av}$ , in dimensionless form is

$$P_{av}/\gamma d = A_1 \lambda$$

Typical results about the failure surfaces are shown in Figs.14 and 15. The extent of failure surface increases with the increase of slenderness ratio. Net uplift capacity factors,  $A_1$ , are given in Fig.16. It is seen that at any value of  $\delta$ , the coefficient,  $A_1$ , increases from zero at  $\lambda = 0$ , to a peak value and thereafter decreases gradually with an increase in slenderness ratio. Average skin friction values are shown in Fig.17. At any value of  $\delta$ , it is seen that the average skin friction increases to a maximum value corresponding to a certain  $\lambda$  value designated as critical  $\lambda$  value. The average skin friction decreases beyond it. The coefficient of net uplift capacity factors  $A_1$  in terms of design charts for values of  $\phi$  between  $25^\circ - 45^\circ$ , and  $\delta$  varied from  $10^\circ$  to  $45^\circ$ , and slenderness ratios  $\lambda = 10 - 100$  are presented for the convenience of the practicing engineers elsewhere (Chattopadhyay and Pise, 1985). Corrections for local, mixed and general shear have been suggested.

#### Remarks

A theoretical model, which is quite versatile for predicting the failure surface inside the soil mass along with the uplift capacity of piles in sand,

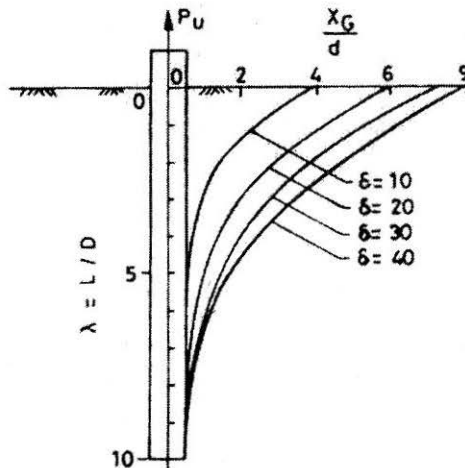

FIGURE 14 : Variation of Failure Surface for  $L/D = 10$  for Different Values of ' $\delta$ ' ( $\phi = 40^\circ$ ) (Chattopadhyay and Pise, 1986)

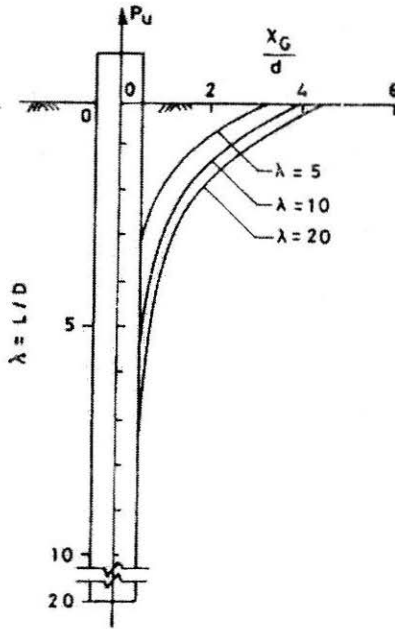

FIGURE 15 : Failure Surface for Different Slenderness Ratios ( $\phi = 40^\circ, \delta = 10^\circ$ ) (Chattopadhyay and Pise, 1986)

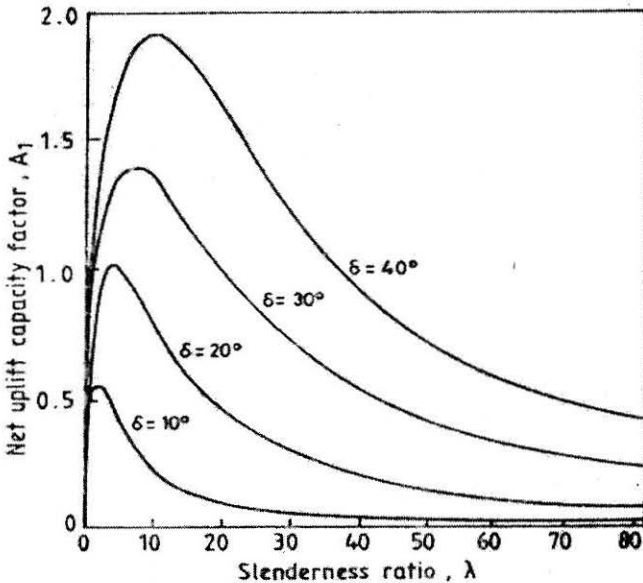

FIGURE 16 : Net Uplift Capacity Factor,  $A_1$  vs. Slenderness Ratio,  $\lambda$  ( $\phi = 40^\circ$ ) (Chattopadhyay and Pise, 1986)

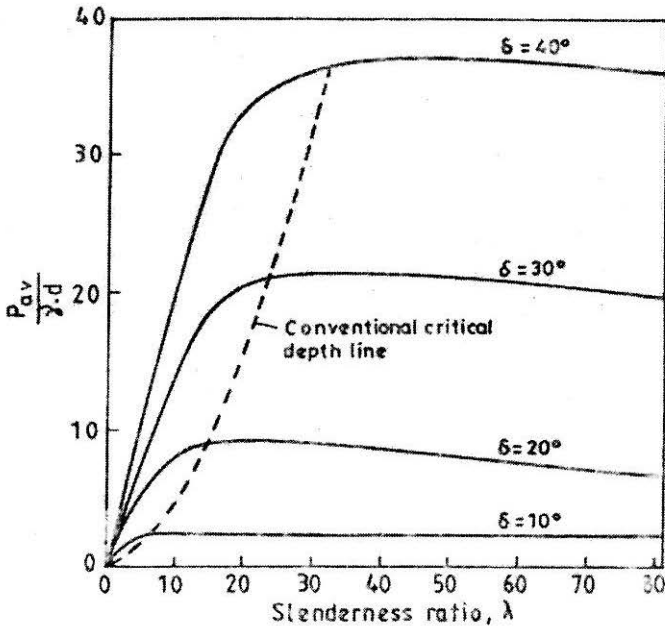

FIGURE 17 : Average Skin Friction vs. Slenderness Ratio,  $\lambda$  ( $\phi = 40^\circ$ )  
(Chattopadhyay and Pise, 1986)

is described. It enables a reasonably logical analysis and the quantitative estimates to be made of the effects of parameters like length to diameter ratio, pile friction angle, and angle of shearing resistance on the ultimate uplift capacity as well as on average skin friction values. The analysis can also predict the critical depth of embedment beyond which the average skin friction attains a constant value. The critical depth not only depends on  $\phi$  but also on  $\delta$ . An illustrative comparison has been presented later for clarity.

### Experimental Investigations

To assess the usefulness and applicability of the analytical method proposed, Chattopadhyay (1986) carried out tests in the laboratory in a model tank of size 914 mm  $\times$  762 mm  $\times$  914 mm on embedded model piles. Dry Ennore sand, having  $G = 2.67$ , uniformity coefficient 1.1,  $e_{\min} = 0.59$  and  $e_{\max} = 0.92$ , corresponding unit weights 1.67 g/cc and 1.39 g/cc, respectively was used as foundation medium. The placement unit weight during testing was 1.61 g/cc, RD = 75% and  $\phi = 41^\circ$ . Aluminium open-ended tubular piles with outer diameters 20.5 and 21.4 mm were used as smooth and rough piles, respectively. Soil-pile friction angles  $\delta$  were  $15^\circ$ ,  $34^\circ$ , and  $37^\circ$  respectively for smooth, medium rough and rough piles. For each type of

piles three lengths, 246 mm, 496 mm and 744 mm were used. The schematic diagram of the testing set-up is similar to that used by Patra (2001) and given later. The loading arrangement and placement of dial gauges is also shown in the sketch. The ultimate loads have been estimated from the load-displacement diagrams. The ultimate resistance is taken as the load at which the pile moves out of the soil i.e., pull versus axial movement curve becomes parallel to the axial movement axis. The experimental results have been utilised to compare them with the predicted values using the generalised uplift capacity theory discussed earlier. From the experimental results Cattopadhyay (1986) concluded that for smooth piles very large movement of about  $0.3d$  to  $0.75d$  was required to mobilise the ultimate resistance, lower values are for short piles and higher ones for long piles. 50% of ultimate capacity is mobilised at about  $0.025d$  axial movement. Rough piles, irrespective of their lengths, axial movement was within  $0.10d$  -  $0.15d$  at failure. Ultimate resistance increases, nonlinearly, with length for all piles.

### *Illustrative Comparison*

#### *Model Test Results of Das (1983)*

He reported uplift test results of rough wooden piles of 2.54 cm diameter in sands for slenderness ratio of 4 to 24. The relative densities of sand used were 22%, 48% and 73%, the corresponding values of  $\phi$  were  $31^\circ$ ,  $34^\circ$  and  $40.5^\circ$ , and  $\gamma = 1.51$  g/cc, 1.61 g/cc and 1.72 g/cc, respectively. Net uplift capacities of piles were predicted by taking  $\delta$  as  $30^\circ$ ,  $32^\circ$  and  $38.5^\circ$  for the respective test conditions. Remarkably closer agreement was noted between the predictions and observed values. Also the observed nonlinear variation of net uplift capacity with slenderness ratio was reasonably predicted by the theory.

#### *Field Test - Results of Ismael and Klym (1969)*

They reported a full-scale test under uplift of a cylindrical pier of diameter 1.07 m and length 6.4 m, embedded in a compact fine to medium sand with some silt and traces of clay. The average  $N$  value reported was 20 and  $\phi = 34^\circ$ . Submerged unit weight was 1.1 g/cc. Assuming  $\delta = 27^\circ$ , the predicted gross uplift capacity of the pier was 969 kN, which is closer to the measured value of 889 kN.

They have also compared the predictions by the analytical method with a number of available laboratory results including theirs and also a few field results. Also, they compared their predictions with the available analyses (Meyerhof, 1973). Amongst the available theories the proposed analysis predicts reasonable values of ultimate uplift resistance and average skin friction indicated by comparison with the reported test results.

### Chattopadhyay and Pise (1987)

Modifications have been suggested to estimate the uplift capacity of driven pile from the generalized theory published earlier (1986). It is assumed that during driving of the pile in sand compaction takes place around the pile. Investigations on the extent of compaction of sand and increase in relative density of sand around pile have suggested that the compacted zone around pile is  $7d$ . Within this zone, angle of shearing resistance changes linearly with distance from the original value of  $\phi$  at a radius of  $3.5d$  to a maximum of  $\phi_1$  at the pile tip as

$$\phi_1 = (\phi + 40^\circ)/2$$

When  $\phi = 40^\circ$ , there is no change in value of  $\phi_1$  due to pile driving (Kishida, 1967)

Therefore angle of shearing resistance and pile friction angle get modified. It is suggested that angle  $\phi$  be taken as given by Kishida (1967) and soil-pile friction angle is estimated depending on the pile material, its surface characteristics and location of water table (Potyondy, 1961).

#### *Illustrative Comparison*

1. The results of rough steel pipe piles driven in dry sand are reported by Awad and Ayoub (1976). The outside and inside diameters of the piles were 25 mm and 21.8 mm with 750 mm driven depth. Taking  $\gamma = 1.447 \text{ g/cm}^2$  and  $\phi = 36^\circ$ , the prediction for net uplift capacity has been done. Modified values of  $\phi_1 = 38^\circ$  and  $\delta = 29^\circ$ . The predicted net uplift capacity = 41.5 kg (Reported capacity = 41 kg).
2. Uplift capacity tests on identical field piles, placed to same depth of embedment by different procedure, in uniform beach sand are reported by McClelland (1974). A 508 mm diameter steel pipe pile was driven to a depth of 14.63 m. Assuming medium dense sand, the initial value of  $\phi = 32^\circ$ . The modified values of  $\phi_1 = 36^\circ$ , and  $\delta = 29^\circ$ . The predicted net uplift capacity is 43 ton (Reported capacity = 47 ton). The predicted values of the uplift capacities are remarkably closer to the reported values.

### Madhav (1987)

He has studied theoretically the interaction between two identical piles in tension by modeling the soil as a homogeneous, linearly elastic medium and by using the boundary integral technique. The reduction in individual



capacity due to the existence of another pile is quantified and found to depend on the spacing and length to diameter ratio of the pile and type of variation with depth of pile-soil interface strength. Efficiencies of typical pile groups are compared. The predictions compare well with model and full-scale test results. Typical values of group efficiencies for  $3^2$ ,  $5^2$ ,  $7^2$  and  $9^2$  are given.

### **Sharma and Soneja (1987)**

They carried out investigation wherein the pile is subjected to uplift load at the top i.e. at pile head, as well as, at the pile toe. Two sets of cast-in-situ short bored concrete piles of 225 mm diameter and 2130 mm long embedded in moist silty sand, having  $\phi = 30^\circ$ . They found that the skin friction is higher for piles pulled from toe than piles pulled from top.

### **Siddamal (1989)**

He has carried out experimental investigations on model pile groups subjected to uplift loads in Ennore sand, having uniformity coefficient 1.1,  $\phi = 40^\circ$  and  $\gamma = 1.61$  gm/cc. Mild steel solid rods of 20 mm diameter, having  $\delta = 23^\circ$  were used to form pile groups.  $1 \times 1$ ,  $2 \times 1$  and  $2 \times 2$  pile groups with variable spacing of piles,  $2d$  to  $8d$ , and  $L/d = 7, 10, 20$  and  $40$  were tested under uplift load. Load-displacement response, net uplift capacity, interaction factors and pile group efficiency have been studied for different variables like spacing of piles in group, embedment depth, group size and arrangement of piles in groups. He concluded that axial displacement of  $0.25d$  to  $0.30d$  is required to mobilize peak uplift resistance. Net uplift capacity of pile group increases with increase in depth of embedment. Group efficiency decreases with increase in the size of the group. The group efficiencies are in the range of 0.73 to 1.00 in case of  $2 \times 1$  group and 0.51 to 0.75 in case of  $2 \times 2$  group.

### **Ruffier and Mahler (1989)**

They carried out a finite element simulation of the uplift of plates and foundations. Several tests performed in tropical residual soils were simulated. Both, soil nonlinearity and plastification were taken into account. The model idealised to represent this system consisted of the soil, the structure and the interface between soil and structure. Joint elements were used to accommodate the relative displacement between soil and structure when an axial load increment was applied. The nonlinear stress dependent stress strain characteristics of the soil was considered. A hyperbolic stress strain relationship was adopted using the tangent value of Young's modulus and Poisson's ratio. The nonlinear effect was incorporated by adopting the incremental iterative Newton Rapson procedure. The finite element method

had been applied to analyze the behaviour of pier foundations subjected to uplift forces. Circumferential plates footings and two kinds of pier foundations with and without enlarged base were considered in the investigation. The predicted shape of failure surface clearly showed, for plates and footings, that the failure process started at the extreme of the base. For pier foundations the process started around the pier base and moved along the shaft towards the surface.

### **Dickin and Leung (1990)**

They presented assumed failure mechanisms for belled piers as suggested by different authors. They studied the influence of embedment, base diameter, and density on the pullout behaviour of piles with enlarged bases embedded in sand in a centrifuge. Several stainless steel piers were employed with bells ranging in diameter from 15 to 76 mm and a maximum depth of 200 mm. Dry Erith sand was used as foundation medium. They found that the uplift capacities in loose sand were considerably lower than those previously observed for anchor plates. Some theories of anchor considerably over predicted the capacity in both loose and dense sand.

They expressed the net ultimate uplift resistance  $Q_u$  in terms of breakout factor  $N_u$  as,

$$N_u = Q_u / A_b \gamma L$$

where  $A_b$  = area of the bell

They summarised the formulation of breakout factors proposed by a number of researchers in their paper.

### **Turner and Kulhawy (1990)**

They carried out experimental study of the effects of repeated loading on drained uplift capacity of drilled shafts in granular soil. The mechanisms causing changes in drilled shaft resistance were identified and the effects of initial soil density, shaft depth to diameter ratio and the magnitude of repeated loading were evaluated. Changes in uplift capacity were found to depend primarily upon the magnitude of cyclic displacement. Critical levels of loading were established above which shafts failed in uplift and below which failure did not occur. Implications for design of drilled shafts under repeated axial loading were presented.

### Joshi and Achari (1992)

Model piles were tested in dry uniform sand to study the effect of loading history on the behaviour of piles in compression and tension. A smooth cylindrical instrumented pile was driven into the sand. The pile was made of a mild seamless pipe of 50.8 mm outside diameter. The effects of length to diameter ratio and sand density were investigated. A significant decrease in the pile capacity both in tension and compression was noted for piles having loading history. The ultimate failure load for piles in tension was in the range of 53 - 84% of the virgin tension capacity. The ultimate shaft capacity in tension was significantly lower than that mobilized in compression. When a pile was loaded in compression after being loaded in tension the tip load could be mobilized only after a certain movement of the pile. The mobilization of the shaft load, however, started immediately.

### Sharma and Pise (1994)

Tests are conducted on two types of piles i.e. straight shafted and with enlarged base. By varying parameters like base enlargement to shaft diameter, surface roughness and  $L/d$ . Ennore sand of placement density of 1.6 gm/cc and  $\phi = 38^\circ$  was the foundation medium. Soil-pile friction angles  $\delta$  were  $30^\circ$  and  $35^\circ$ . Model piles were made of mild steel rods of diameter 12.7 mm and 19.05 mm. Base diameter  $B$  to shaft diameters  $d$  ratios were 1, 2 and 3. Embedment depths were 254, 381, 508 and 635 mm. It is reported that the load-displacement is nonlinear and practically similar for all piles. For smooth piles relatively larger movements have occurred before ultimate capacity is reached. The net uplift capacity increases non-linearly with embedment depth. Rough piles offer more resistance than smooth ones. It increases with  $B/d$  and the increase is maximum at larger depths. At same depth of embedment the net uplift capacity increases roughly linearly with  $B/d$ . The uplift capacity ratio, i.e. net uplift capacity of enlarged base pile to net uplift capacity of straight shafted pile, increases with depth initially and then gradually decreases. In most of the cases, the ratio attains a maximum value at about 400 mm. The percentage increase in capacity from smooth to rough pile is less for higher  $B/d$  ratio than lower  $B/d$  ratio.

They have analysed their results by using the methods suggested by Meyerhof and Adams (1968), referred as Method 1, Sharma et al. (1978), Method 2, Chandra Prakash (1980), Method 3, and Method 4, as proposed by them. The proposed Method 4 is described briefly for ready reference here. The net uplift capacity of the anchor pile is taken as the sum of the resistance given by the following expression,

$$P_{un} = A_1 \gamma \pi d L^2 + \gamma L N_q A \quad (23)$$

where  $A_1$  = net uplift capacity factor given by Chattopadhyay and Pise (1985, 1986) for piles.

$N_q$  = breakout factor for horizontal anchor plates given by Chattopadhyay (1986).

$A$  = annular area of the base enlargement expressed as  $\pi/4(B^2 - d^2)$

Design charts for  $A_1$  have been given by them (Chattopadhyay and Pise, 1985, 1986) for different values of  $\phi$ ,  $\delta$ , and  $\lambda = L/d$ . The breakout factors  $N_q$  are presented by them elsewhere (Chattopadhyay (1986)) through Figures. They are function of  $L/B$  and  $\phi$ .

It is reported that the test results are in closer agreement with the values of uplift capacities estimated by Method 4 than those predicted by other methods discussed above. Method 4 estimates values, which are off by +20% from the test results. Methods 1 and 3 are more conservative. Method 2 predicts scattered values over wide range i.e. theoretical predictions vary from 0.5 to 1.5 times the test results. They also compared the results with the field pile test results of Chandra Prakash (1980). The observed field net uplift capacity of 18.17 ton was closer to that of 16.95 ton as predicted by Method 4. The predictions by methods 1, 2 and 3 were 18.70, 38.10 and 24 ton respectively.

### **Chattopadhyay (1994)**

Chattopadhyay carried out model tests on group of piles, of 1, 2 × 1, 3, 2 × 2 configuration. Aluminium piles of 19 mm outside dia., center to center spacing of 2d to 6d were used. The embedment lengths varied from 300 to 600 mm. Locally available brownish grey dry Mogra sand at and wet blackish grey clayey silt, both having placement densities of 1.70 g/cc were used as soil media. The uplift resistance and the efficiency of the groups are investigated. It is concluded that in sand the efficiency attains a peak value, greater than 100% at closer spacing and it depends on length and configuration of the group. Isolation spacing is about 6d. In compacted cohesive soil it is less than 100% at closer spacing and becomes roughly 100% at about 6d spacing.

### **Das, Mukherjee and Venkatnarayana (1995)**

They presented experimental investigation on pullout resistance of single piles embedded in Ennore sand. Aluminium pipes were used as model piles. The values of  $\phi$  and  $\delta$  ranged between 34 - 37° and 18 - 21°. Tests were carried out on piles of variable slenderness ratio, diameters, density of foundation medium and two surface characteristics (Table 3). An attempt was

TABLE 3 : Test Parameters Used

Pile Diameter, mm	25.4, 38.1 and 50.08
Slenderness Ratio, $L/d$	15, 20 and 25
Density of sand, $\gamma$ ( $t/m^2$ )	1.53, 1.57 and 1.62
Pile surface	Smooth and Rough

also made to find out the failure surface around the piles and empirical equations of the surface so formed. It was concluded that the load-displacement response is nonlinear and becomes ultimately asymptotic to the displacement axis. Rough piles offer more resistance. Maximum load before failure occurs at a movement of 3% to 5% of its diameter for smooth and rough piles.

### **Nagaraju and Pise (1995)**

They have reported model test results on the behaviour of single piles embedded in layered sand under inclined pulling loads. Aluminium alloy tubes of 19 mm outside diameter and  $L/d = 12$  and 38 were tested in dry Ennore sand. The qualitative and quantitative effects of the various parameters have been studied. It is observed that the increase in depth of dense layer or loose layer at the top increases or decreases the axial uplift capacity significantly.

### **Pise (1996)**

He has reviewed some of the existing approaches used to predict the uplift capacity of piles in sand. Applicability of the generalized theory given by Chattopadhyay and Pise (1986) has been discussed and its extension to enlarged based piles is described (Sharma and Pise, 1994). Applicability of the theoretical results and equations has been explained.

### **Mukherjee (1996)**

Mukherjee carried out experimental and theoretical investigations to study the pull out behaviour of pile groups in sand. An attempt has been made to find out the failure surface profile around the group through experimentally and using finite element method.

Experiments were carried out with different pile groups varying different parameters, namely, pile spacing, length to diameter ratio,

arrangement of piles in the group. The load distribution in the piles and along the length of the piles and the total load carried by the group was measured indirectly by using strain gauges and load cells. Aluminium pipes of 25.4 mm outer diameter and 21 mm inner diameter were used as piles. Pile friction angle was  $21^\circ$ . Uniform dry Ennore sand, obtained from Tamilnadu of  $D_r = 88\%$ , unit weight  $1.62 \text{ t/m}^3$  and corresponding angle of shearing resistance  $37^\circ$  was used as foundation medium. The tests were carried out in a segmented tank of size  $900 \times 900 \times 1100 \text{ mm}$  deep. Line groups of  $1 \times 2$ ,  $1 \times 3$ , triangular group, square and rectangular groups of  $2 \times 2$ ,  $2 \times 3$  and  $3 \times 3$  along with a single pile were tested. The different variables used were embedment length and spacing of piles in the group. 54 tests were carried out on groups and 3 on single piles.

The failure surface developed inside the foundation medium was found, by locating the breaking points of some fragile material (vermicelli), already placed radially inside the foundation bed around the pile groups, at different locations and levels. The theoretical failure surface was predicted by making suitable simplified assumptions and employing finite element method. The ultimate uplift capacities were investigated both experimentally and theoretically.

He concluded that uplift capacity increases with increase in length of the pile. The uplift capacity increases with increase in spacing of piles in the group. The group efficiency decreases with increasing embedment ratio but increases with increasing spacing for a particular group. At failure the central piles carry the least and the corner piles the highest load. The load transferred to the soil is more at the top and gradually reduces to minimum with increase in depth. At failure more than 80% of the load is transferred to the foundation medium within the top half of the embedment length of the pile. The shape of the observed failure surface is curvilinear and concave downwards for shallow groups, embedment ratio  $< 6$ , while convex downwards for deep ones, embedment ratio  $> 6$ . For deep ones, the height of failure surface extends up to about 20 times the pile diameter above the tip and the lateral distance from the piles/pile groups periphery to the topmost failure of curved portion is around 8 - 10 times the pile diameter.

### **Ilamparuthi (1998)**

He reported the pullout test on model buried pile anchor of diameter 38.1 mm and length 312 embedded in sand having  $\phi = 48^\circ$  and  $34^\circ$ . The results showed that the load-displacement response curves were of two independent characteristics depending on the depth of embedment. The influence of buried depth and density on pullout capacity was brought out. Contribution of top resistance to total resistance increases with increase in embedment ratio irrespective of density, whereas frictional resistance decreases with embedment ratio.

### **Alawneh, Malkawi and Al-Deeky (1999)**

Sixty-four pullout tests were conducted on open and closed-ended rough and smooth model piles of 41 and 61 mm diameter. The model piles were installed in medium dense and dense sand to an embedded depth of 0.8 m by static jacking and driving. The values of  $\phi$  and  $\gamma$  were 39 and 48 and  $15.2 \text{ kN/m}^3$  and  $16.4 \text{ kN/m}^3$  depending on the compaction of sand. The results indicated that pile placement method, initial sand condition, pile surface roughness, and pile end type are all significant variables affecting the ultimate uplift shaft resistance of a single pile in dry sand. Overall, the closed-ended piles showed 24% increase in shaft resistance compared with the open-ended piles. Average unit shaft resistance of the driven model pile was 1.33 times that of the jacked model pile in the dense condition and 1.52 times in medium dense sand condition. Depending on the test variables, the rough piles experienced a 12 - 54% increase in capacity compared with the smooth model piles. Also, the lateral earth pressure coefficient values for the rough model piles were greater than those for the smooth piles. This suggests that part of the increase in capacity due to pile surface roughness is attributed to an increase in the radial effective stress during tensile loading. This implies that pile surface roughness enhances the tendency of the sand to dilate during uplift loading, which in turn increases the magnitude of the radial effective stress against the pile surface.

### **Patra and Pise (1999)**

They investigated model pile groups  $1 \times 1$ ,  $2 \times 1$  and  $2 \times 2$  for various spacing, surface characteristics and placement densities under uplift loads. Aluminium tubes of outer diameter 19 mm and  $L/d = 12$  were used as model piles. Tests were conducted in dry Ennore sand obtained from Madras, India. The placement densities during testing were  $1.56 \text{ t/m}^3$  and  $1.64 \text{ t/m}^3$  (RD = 50% and 80%) and the corresponding angle of shearing resistance were  $33^\circ$  and  $37^\circ$ . Generally the load- displacement curves are non-linear and asymptotic in nature. Rough piles offer more resistance than smooth piles. Axial displacement of order 0.5 to 3 mm for smooth piles and 1 mm to 5 mm for rough piles were observed. The ultimate uplift resistance for the pile group increases roughly linearly with spacing. The variation of uplift capacity of pile groups is expressed by group efficiency. For  $2 \times 2$  pile groups, the group efficiency increases with increase in pile spacing. It varies from 100 to 130%. For  $2 \times 1$  pile group it increases with increase in spacing upto  $4.5d$  spacing and then remains practically constant.

### **Sathyanarayana (2000)**

Sathyanarayana carried out experimental investigation in the laboratory to study the behaviour of enlarged base piles embedded in layered sand

subjected to axial uplift load. Mild steel tubes of 25 mm outside diameter and wall thickness 2 mm were used as model piles. The embedment length to diameter ratio of 8, 16, 20 and 24 and base to shaft diameter ratio of 1, 2 and 3 were used. They were tested in sand of loose over the dense condition, having ratio of dense layer to length of a pile as 0.0, 0.25, 0.5, 0.75 and 1.0. The influence of the various variables used in the experimentation have been quantitatively and qualitatively investigated on the load-displacement response and ultimate uplift resistance. He also suggested a simplified approach to estimate the uplift capacity of the piles based on the work carried out by Sharma and Pise (1994). The observed values of the ultimate resistance are in closer agreement with predictions made by the proposed method. He concluded further that the uplift capacity increases with increase in length, base enlargement and thickness of dense layer. Axial displacement in the range of 2.5 to 3.0 mm for straight shafted piles and more for enlarged base piles are required to mobilize the ultimate resistance.

### **Patra (2001)**

Patra has carried out laboratory investigation to study the behaviour of pile groups under uplift loads. He has also suggested the analytical method to predict the uplift capacity of piles under axial uplift loads. The investigation being very useful and data-base, is discussed in details.

### ***Experimental Investigation***

Experimental investigations on model pile groups of configuration ( $2 \times 1$ ,  $3 \times 1$ ,  $2 \times 2$ ,  $3 \times 2$ ) along with a single pile subjected to vertical uplift loads were conducted in dry dense sand. Figure 18 shows the schematic sketch of the experimental set up. Uniform sand was used as a foundation medium in a model tank of size 914 mm  $\times$  762 mm  $\times$  914 mm deep. The specific gravity and uniformity coefficient of the sand were 2.64 and 1.6 respectively. The unit weight of the sand during testing was 16.4 kN/m<sup>3</sup> (relative density = 80%). The corresponding angle of shearing resistance  $\phi = 37^\circ$ . The embedment length to diameter ratios of  $L/d = 12$  and 38, center to center spacing of piles in the groups 3d, 4.5d and 6d and two surface characteristics were used. Aluminium alloy tubes of 19 mm outer diameter, 0.81mm wall thickness were used as model piles. The length to diameter ratios of piles were 12 and 38. The soil-pile friction angle  $\delta$  between smooth and rough surfaces of piles and sand were  $20^\circ$  (referred as smooth) and  $31^\circ$  (referred as rough) for the test condition of sand used. Aluminium plates of 40 mm width, 30 mm depth and variable lengths were used as pile caps for pile groups. The piles could be put in vertical position at the required spacing of 3, 4.5 and 6 times the diameter of piles in the pile caps. Typical diagrams of uplift load versus axial displacement are shown in Fig.19.



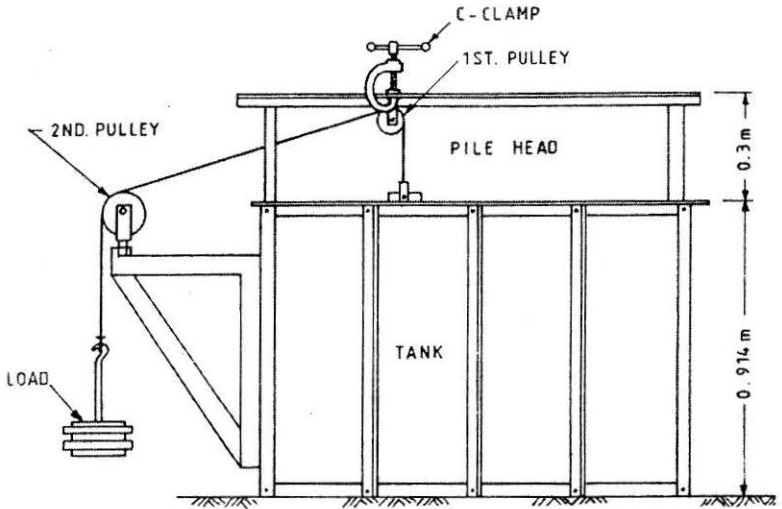

FIGURE 18 : Schematic Diagram of Experimental Assembly (Patra, 2001)

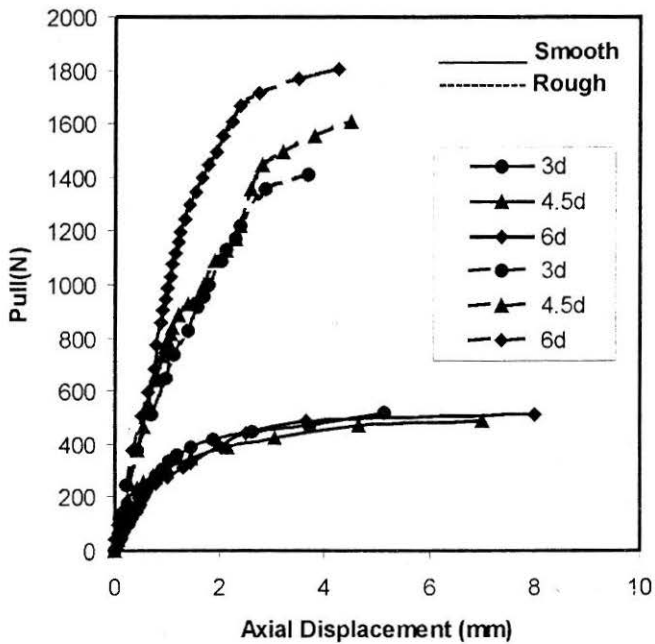

FIGURE 19 : Uplift Load vs. Axial Displacement ( $3 \times 2$  Pile Group,  $L/D = 38$ ) (Patra, 2001)

### *Analysis of Results*

A simplified method has been developed in this section to analyse the observed results. The proposed method is based on the reported analysis of Meyerhof and Adams (1968) for the group of footings and shafts.

### *Single Pile Capacity*

The single pile capacity has been evaluated as suggested by Chattopadhyay and Pise (1986). They have derived an expression for the gross and net ultimate uplift resistance of a single pile. They considered the variables like the angle of shearing resistance ( $\phi$ ), soil-pile friction angle ( $\delta$ ) and  $\lambda = L/d$  ratio in the analysis. The analysis has been presented earlier in the paper.

The net uplift capacity of a single pile is expressed as (Chattopadhyay and Pise, 1986),

$$Q_u = \gamma L^2 A_1 \pi d$$

where  $A_1$  = net uplift coefficient factor as given by Chattopadhyay and Pise (1986)

The values of the net uplift capacity factors  $A_1$  for different slenderness ratios,  $\lambda$ , and soil-pile friction angle,  $\delta$ , are given by Chattopadhyay and Pise (1985, 1986)

### *Pile Group Capacity*

It is approximately assumed here that under the action of uplift force, the pile group capacity is contributed by three parts (Fig.20). These are (i) the central portion including the piles and the enclosed soil mass (ii) half the edge portions and (iii) the weight of the soil enclosed in the central portion. As an illustration, for  $2 \times 1$  pile groups (Fig.20), Inoq is the central portion and lmn and opq are the edge portions.

#### *Uplift Resistance Offered by the Central Portion*

The central portion it is considered as pier in the simplified analysis. The uplift resistance of the central portion is approximately expressed (Meyerhof and Adams, 1968) as

$$Q_{uc} = \gamma L^2 [k(a+b)] \quad (24)$$

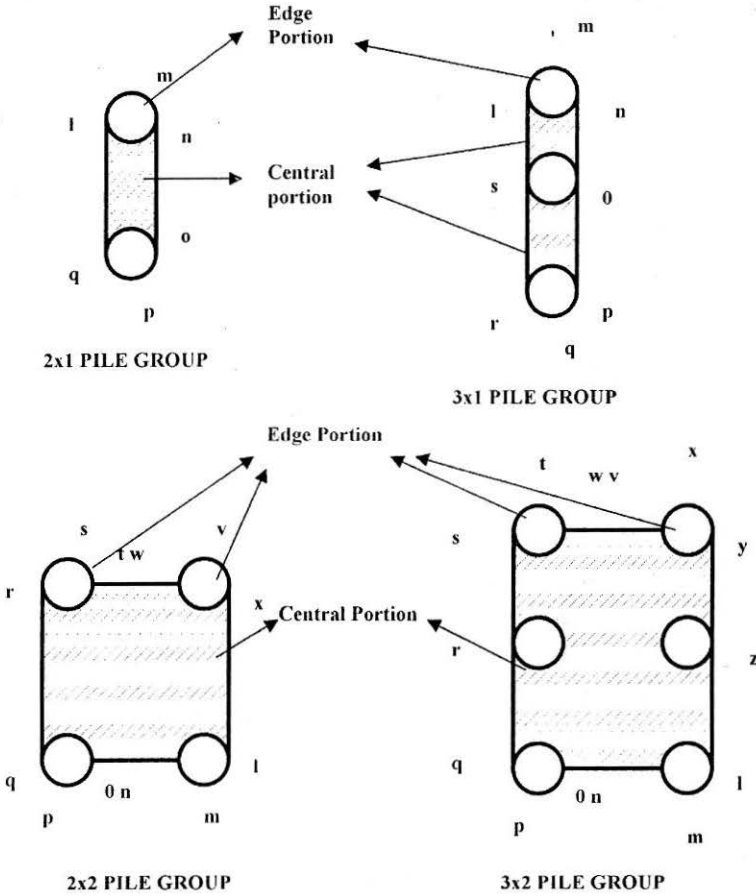

FIGURE 20 : Schematic Diagram of Pile Groups Showing Different Zones (Patra, 2001)

where

- $Q_{uc}$  = uplift resistance offered by the central portion
- $a$  = center to center distance of the piles along the length
- $b$  = center to center distance of the piles along the width
- $k$  = vertical component of earth pressure coefficient governing the uplift resistance generated along the central portion of the pile group.

From the experimental observations, it has been found that the soil between the piles is lifted up for pile spacings  $3d$ ,  $4.5d$  and  $6d$ . The vertical component of the earth pressure coefficient ' $k$ ' governing the uplift resistance generated along the central portions of the pile groups is assumed as

$$k = (1 - \sin \phi) \tan \delta / \tan \phi \quad (25)$$

The assumption of  $k$ , has been made for the pile group spacing varying from  $3d$  to  $6d$  and includes the influence of soil-pile friction angle,  $\delta$ , on the uplift capacity.

The central portions of the groups are shown in Fig.20. These are 'lnoq' for  $2 \times 1$ , 'lnpr' for  $3 \times 1$ , 'lqrx' for  $2 \times 2$  and 'lqrsyz' for  $3 \times 2$  groups.

#### *Uplift Resistance Offered by the Edge Portions*

The uplift resistance governed by the edge portions of the pile groups, 'lmn' and 'opq' for  $2 \times 1$ , 'lmn' and 'pqr' for  $3 \times 1$ , 'lmn', 'opq', 'rst' and 'wvx' for  $2 \times 2$ , 'lmn', 'opq', 'stw', 'vxy' for  $3 \times 2$  is taken as equivalent to that contributed by half of the piles. Taking the slenderness ratio,  $\lambda$ , angle of shearing resistance,  $\phi$ , and soil-pile friction angle,  $\delta$ , it is evaluated by the expression given by Chattopadhyay and Pise (1986) for a single pile.

$$Q_{uc} = n(\pi d)A_1 \gamma L^2 \quad (26)$$

where  $Q_{uc}$  = uplift resistance offered by the edge portions of the pile groups

$n$  = number of half piles in the edge portions

The values of net uplift capacity factor  $A_1$  for different slenderness ratios,  $\lambda$ , and pile friction angle,  $\delta$ , could be determined from the charts given by Chattopadhyay and Pise (1986).

The gross uplift capacity of a pile group ' $Q_{ug}$ ' can be expressed as

$$Q_{ug} = Q_{uc} + Q_{ue} + W_q \quad (27)$$

Therefore, the gross uplift capacity of the line pile groups,  $2 \times 1$ ,  $3 \times 1$  is,

$$Q_{ug} = \gamma L^2 [k(a+b) + A_1 \pi d] + W_q \quad (28)$$

where  $W_q$  = weight of piles, pile cap and weight of the soil enclosed in the central portion.

Similarly for a square  $2 \times 2$ , and rectangular pile groups  $3 \times 2$ , the

gross uplift capacity is arrived at combining the two line pile groups  $2 \times 1$  or  $3 \times 1$  as,

$$Q_{ug} = \gamma L^2 [k(a+b) + 2A_1 \pi d] + W_q \quad (29)$$

The net uplift capacity of the pile groups could be found out by subtracting the weight of piles, pile cap from the gross uplift capacity.

### **Group Efficiency**

The uplift capacity of a pile group is generally studied by group efficiency ' $\eta$ '. It is expressed as,

$$\eta = \frac{Q_{ug}}{n_1 n_2 Q_u} \quad (30)$$

where

- $Q_{ug}$  = ultimate uplift capacity of pile group
- $Q_u$  = ultimate uplift capacity of single pile
- $n_1$  = number of rows in a pile group
- $n_2$  = number of columns in a pile group

Typical results of efficiency versus spacing diagrams are presented through Figs.21 and 22. The group efficiency, in general, increases roughly linearly with the pile spacing for the spacing 3 to 6d considered in the investigation. The efficiency lies between 50 to 180%. It depends significantly on pile group configuration, spacing, number of piles in a group and the soil-pile friction angle.

### *Comparison of Experimental and Predicted Results*

Typical experimental results of the writers on the net uplift capacity of pile groups for  $L/d = 12$  have been compared with the predictions made by the proposed analysis (Table 4). They have also been compared with the predictions made by using Meyerhof and Adams' (1968) approach. The comparison is depicted in Table 4. The predicted values of the net uplift capacity using Meyerhof and Adams' (1968) approach are much higher than the observed experimental results. The predictions from the present analysis are in closer agreement with experimental values.

The experimental results of Chattopadhyay (1994) and Siddamal (1989) have also been analysed by the proposed analysis.

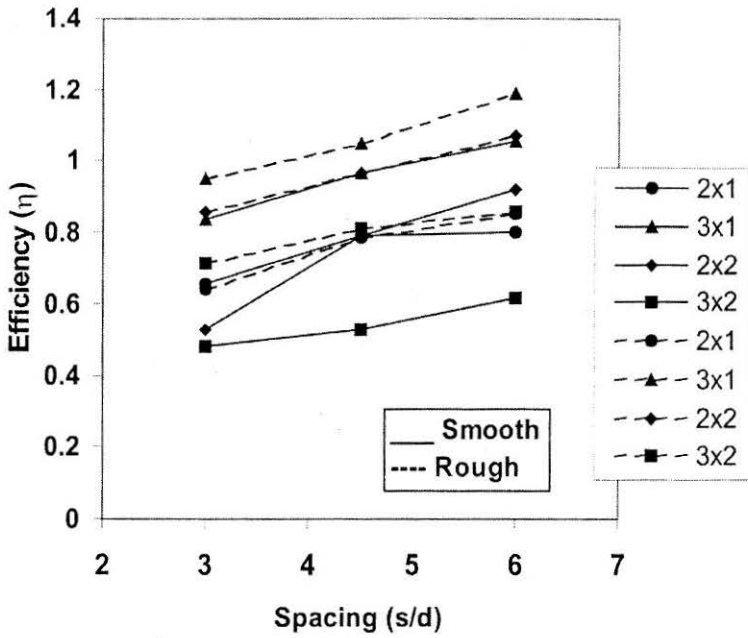

FIGURE 21 : Efficiency vs. Pile Spacing ( $L/D = 12$ ) (Patra, 2001)

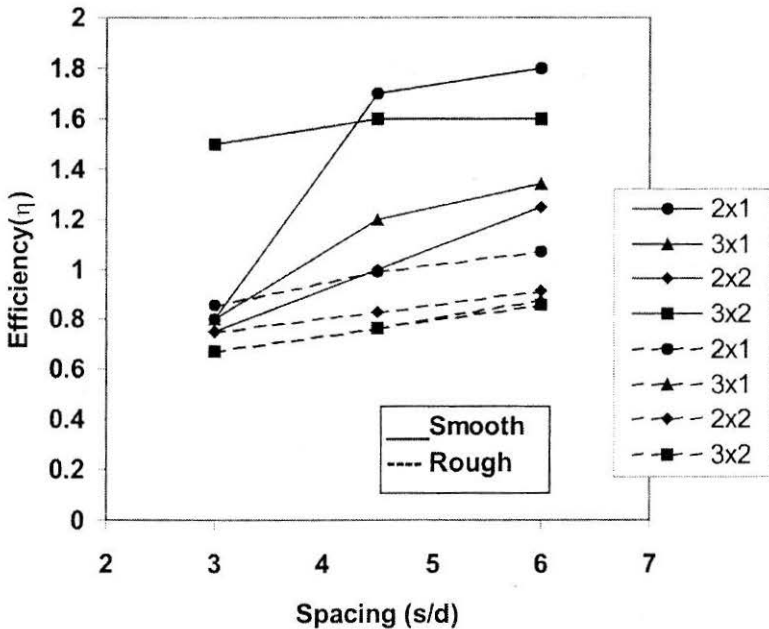

FIGURE 22 : Efficiency vs. Pile Spacing ( $L/D = 38$ ) (Patra, 2001)

TABLE 4 : Comparison with Experimental Results of Patra (2001)

Pile Groups ( $L/d = 12$ )		Predicted Net Uplift Capacity (N) Meyerhof et al. (1968) Method $\delta = 31^\circ$	Predicted Net Uplift Capacity (N) by Proposed Method $\delta = 31^\circ$	Net Uplift Capacity (N) Observed $\delta = 31^\circ$
(1)		(2)	(3)	(4)
Single pile		40	40	35
$2 \times 1$ Pilegroup	3d	78.18	62.83	45
	4.5d	105	71	55
	6d	120	80	65
$3 \times 1$ Pilegroup	3d	113.4	87	80
	4.5d	150	106	110
	6d	200	126	125
$2 \times 2$ Pilegroup	3d	112.8	120	120
	4.5d	158.5	150	135
	6d	214	180	150
$3 \times 1$ Pilegroup	3d	157	150	150
	4.5d	205	200	170
	6d	322	260	180

*Model Test Results of Siddamal (1989)*

Siddamal reported axial uplift test results on model mild steel groups of size  $1 \times 1$ ,  $1 \times 2$  and  $2 \times 2$  having,  $L/d = 7, 20$  and  $40$ . He used spacing 2, 4 and 6 times the pile diameter for  $1 \times 2$  pile group and 2 and 4 pile diameter for  $2 \times 2$  pile group. The diameter of the pile was 20 mm. Dry sand having  $\gamma = 16.1 \text{ kN/m}^3$ ,  $\phi = 40.5^\circ$  and  $\delta = 23^\circ$  was used as the foundation medium. The theoretical and observed net uplift capacities are shown in Table 5. The observed nonlinear variation of the uplift capacity with length is satisfactorily (about  $\pm 10\%$ ) predicted by the proposed theory for  $L/d = 7$  and  $20$ . However, for  $L/d = 40$ , the predictions are about 30% less than the measured values.

*Model Test Results of Chattopadhyay (1994)*

Chattopadhyay (1994) reported uplift test results on model pile groups of size  $1 \times 1$ ,  $2 \times 1$ , 3 and  $2 \times 2$  and  $L/d = 15.78, 23.68$  and  $31.57$ .

**Table 5 : Comparison with Experimental Results of Siddamal (1989)**

Piles / Pile Groups	Spacing	L/d	Net Uplift Capacity (N), Observed by Siddamal (1989)	Predicted Net Uplift Capacity (N) by Proposed Analysis
(1)	(2)	(3)	(4)	(5)
Single Pile		7	21.69	24.9
		20	114.51	128.6
		40	441.63	300
2 × 1 Pile Group	2d	7	34.9	31.8
	4d	7	40.52	34.07
	6d	7	41.4	38.01
2 × 1 Pile Group	2d	20	166.3	160
	4d	20	176	183.6
	6d	20	185.5	204.3
2 × 1 Pile Group	2d	40	795.3	427.6
	4d	40	845.95	510.0
	6d	40	866.12	600.0
2 × 2 Pile Group	2d	7	44.7	39.5
	4d	7	49.0	54.72
2 × 2 Pile Group	2d	20	282.72	323.2
	4d	20	320.0	370.0
2 × 2 Pile Group	2d	40	1102.80	784.3
	4d	40	1211.64	989.5

Aluminium tubes of outer diameter 19 mm were used as piles. The groups were tested for spacing 2.3d, 4d, 5d and 6d. The soil was locally available brownish grey dry Morga sand. The sand was coarse to medium with  $D_{60} = 0.95$  mm,  $D_{10} = 48$  mm and  $c_u = 1.98$ . The unit weight of sand was  $\gamma = 17.00$  kN/m<sup>3</sup>. Typical load displacement diagrams of single pile, 2 × 1 and 2 × 2 pile groups at spacing 2.3d for L/d = 15.78, 23.68, 31.57 were presented by him. From the load displacement diagrams the measured values of the net uplift capacity of pile and pile groups were evaluated. For theoretical calculations  $\phi = 40^\circ$  and  $\delta = 25^\circ$  ( $2/3\phi$ ) were considered. The theoretical and measured net uplift capacities are plotted in Fig.23. The predictions are very close to the line having an equation  $P_{\text{measured}} = P_{\text{Predicted}}$ .



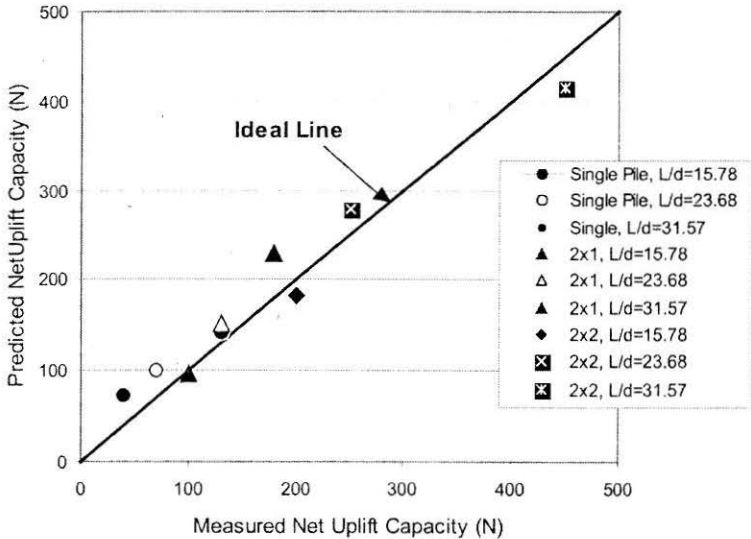

FIGURE 23 : Comparison with Test Results of Chattopadhyay (1994) (Patra, 2001)

### Conclusions from Above Study

The ultimate uplift capacity and also the efficiency of a pile group depends on the embedment length to diameter ratio, pile group configuration, soil-pile friction angle, spacing of piles in a group, and angle of shearing resistance of soil.

The ultimate uplift capacity per pile increases linearly with an increase in spacing. It is attained at a pile head displacement of about 0.5 to 2.5% of pile diameter for smooth pile groups and 1 to 5% of pile diameter for rough pile groups.

For  $L/d = 38$ , rough pile groups, the ultimate uplift capacity per pile decreases with an increase in number of piles in a group and also with the change in pile group configuration from a line to square or to a rectangular group.

The group efficiency, in general, increases roughly linearly with the increase in the spacing. For long rough pile groups, it decreases with an increase in number of piles in a group and change in pile group configuration from a line to square or to a rectangular group. It decreases with an increase in length of piles. It has been found to lie in a wide range of 50 to 180%.

The predicted values of ultimate resistance using Meyerhof and Adams' (1968) approach are much higher than the observed experimental results. The predictions from the proposed method are in closer agreement with the observed experimental values. Closer agreement between the experimental and predicted values has also been noted with the reported results of Siddamal (1989) and Chattopadhyay (1994).

### **Das and Pise (2003)**

Thirty-six tests on model tubular steel piles embedded in sand were carried out in the laboratory to assess the effects of compressive load on uplift capacity of piles considering various parameters. Uniformly graded sand, having uniformity coefficient 1.1 and specific gravity 2.65 was used as a foundation medium. The minimum and maximum dry densities were  $14 \text{ kN/m}^3$  and  $17 \text{ kN/m}^3$  respectively. The average dry unit weight was  $15 \text{ kN/m}^3$  for loose condition ( $\text{RD} = 35\%$ ) and  $16.40 \text{ kN/m}^3$  for dense condition ( $\text{RD} = 80\%$ ). The angles of shearing resistance corresponding to the above placement densities were  $30^\circ$  and  $38^\circ$  respectively. The soil-pile friction angles were  $21^\circ$  and  $28^\circ$  in loose ( $\text{RD} = 35\%$ ) and dense conditions ( $\text{RD} = 80\%$ ) of sand. The model piles were of 25 mm outside diameter and 2mm wall thickness. They were embedded in sand for embedment length/diameter ratios of 8, 16 and 24 inside a model tank. The tests were conducted in a steel tank of size 620 mm  $\times$  600 mm  $\times$  760 mm. They were subjected to a static compressive load of 0%, 25%, 50%, 75% and 100% of their ultimate capacity in compression and subjected to pull out loading tests. The schematic diagram of the experimental set-up is shown in Fig.24. Suitable fabrication was made such as to apply compressive, uplift, and static compressive load along with the uplift load simultaneously by the screw jack loading arrangement, as desired. Sand was poured in the tank by rainfall technique (Patra and Pise, 2001) by initially placing the pile in the tank and the required embedment length to diameter ratio was attained. From the load-displacement the ultimate capacities of piles were estimated.

#### **Test Results**

The load displacement curves were similar at all test conditions. At an early stage of loading, the load-displacement response is practically linear but afterwards it is non-linear. In general, to attain the peak uplift resistance, displacement in the range of  $0.08d$  to  $0.25d$  was required.

It is observed that the net uplift capacity decreases with increase in the stage of compressive loading. In loose sand there is a steep decrease in net uplift capacity at early stage of loading and thereafter the decrease is gradual. Towards the last stage of loading the net uplift capacity practically approaches

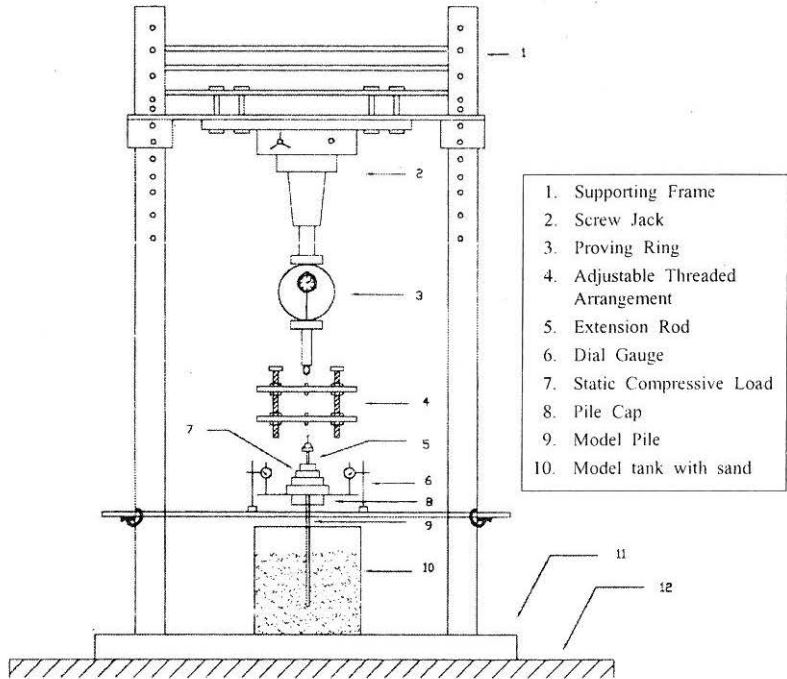

FIGURE 24 : Schematic Diagram of Experimental Set-up  
 (Das and Pise, 2003)

a constant value (Fig.25). In dense medium there is almost a gradual decrease in net uplift capacity with increase in compressive load (Fig.26). Maximum decrease in uplift capacity is observed at 100% stage of compressive loading in both loose and dense sand.

The net uplift capacity at any stage of loading increases with increase in  $L/d$  ratio. At any  $L/d$  ratio the net uplift capacity at higher stage of loading is always less compared to the lower stage of loading.

To analyse the results a logical analytical approach has been suggested. It is assumed that the placement of compressive load on the pile may result in a change in soil fabric at the pile soil interface of a pile. More over as the pile gets pushed inside the soil mass under the action of static compressive load there is no densification of the sand surrounding the pile. So, the effect of the compressive load on the pile only alters the soil-pile friction angle ' $\delta$ ' and soil friction angle ' $\phi$ ' remains unchanged. These assumptions have been made based on a number of studies reported in the literature (Das, 2002). In the analysis the value of ' $\delta$ ' is assumed to vary

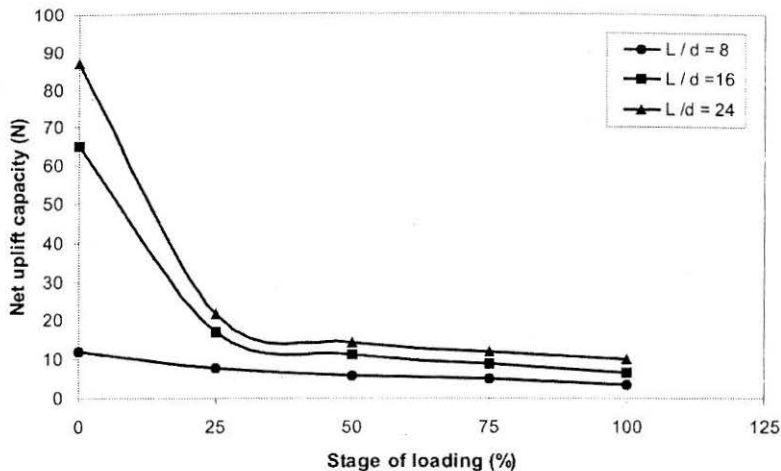

FIGURE 25 : Variation of Net Uplift Capacity with Stage of Loading (Loose Sand) (Das and Pise, 2003)

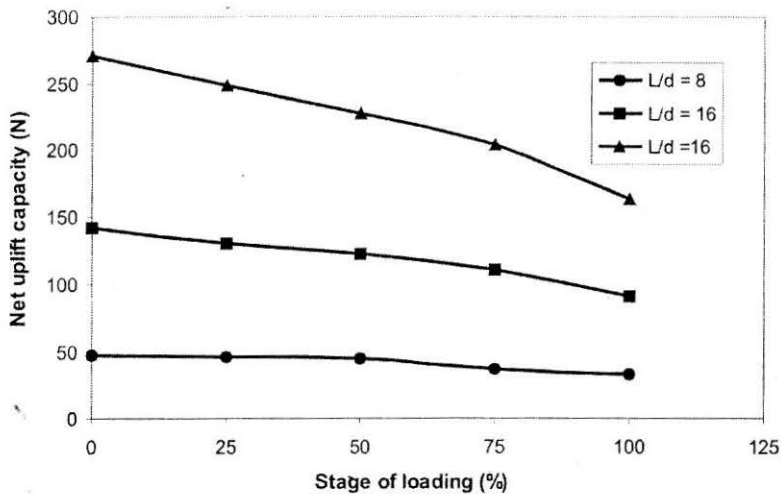

FIGURE 26 : Variation of Net Uplift Capacity with Stage of Loading (Dense Sand) (Das and Pise, 2003)

empirically from its initial value for different stages of loading. Such assumption results into analytical values of net uplift capacity, predicted by using the generalised approach of Chattopadhyay and Pise (1986), remarkably closer to the experimental values (Table 6 and Fig.27) .

**TABLE 6 : Comparison of Experimental Results with Analytical Values [Das and Pise (2003)]**

Sand Density	L/d	Net Uplift Capacity (N) at Different Stages of Loading (Experimental Values)					Values of $\delta$ Assumed for Different Stages of Loading					Net Uplift Capacity (N) at Different Stages of Loading {Predicted from Chattopadhyay and Pise's (1986) Approach}				
		0%	25%	50%	75%	100%	0%	25%	50%	75%	100%	0%	25%	50%	75%	100%
Loose $\phi = 30^\circ$	8	12.2	7.85	5.89	5.20	3.33	21	20	19	18	17	8.33	7.65	5.88	5.20	3.33
	16	65.2	16.9	11.3	8.93	6.57	21	18	16	14	13	28.6	16.9	11.6	8.43	6.96
	24	86.7	21.7	14.2	12.0	10.1	21	14	11	10	09	41.6	21.1	13.8	12.26	10.4
Dense $\phi = 38^\circ$	8	47.6	46.6	44.4	37.5	33.4	29	26	24	21	20	47.4	46.50	45.7	37.18	34.4
	16	142	130	123	110	91	29	27	25	23	21	151.6	134	126	111	92
	24	271	248	228	204	164	29	28	27	26	24	264	249	226	201	166

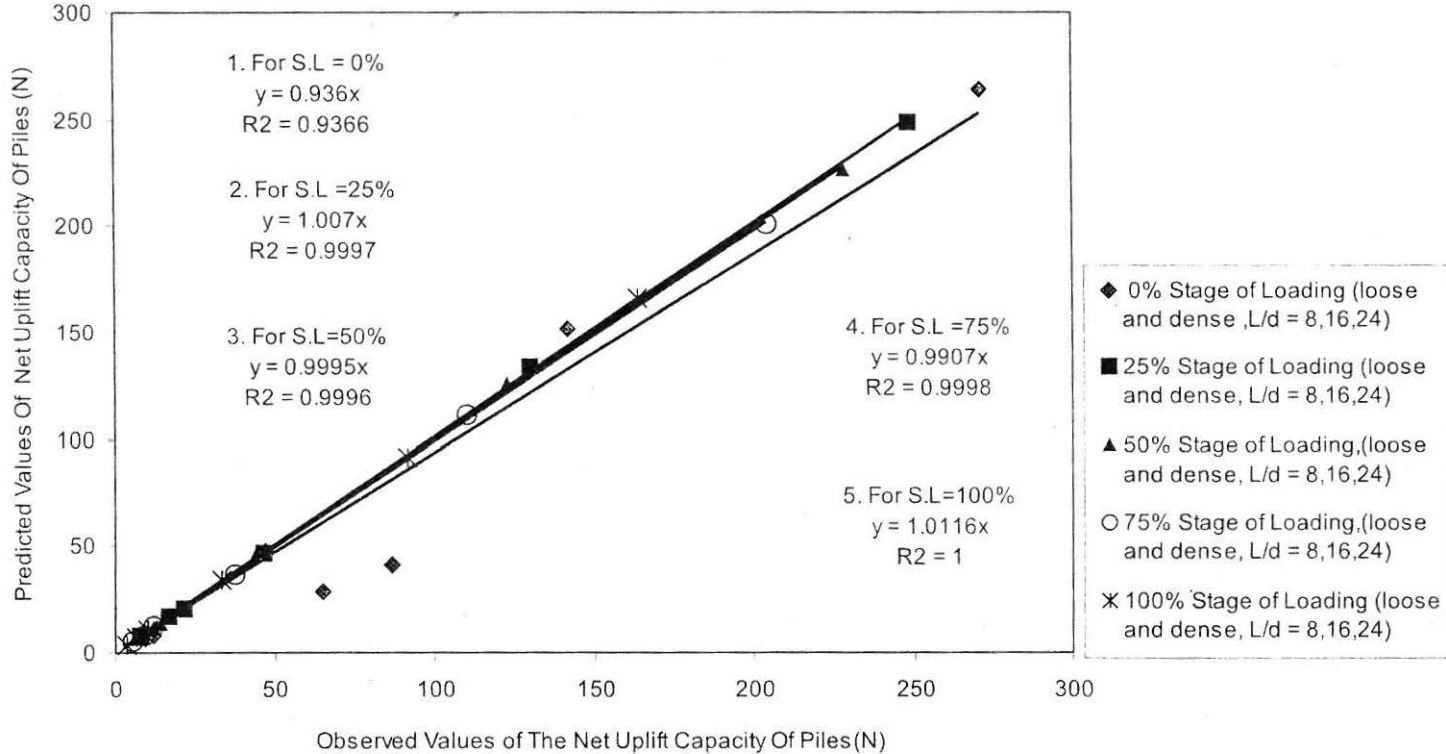

FIGURE 27 : Comparison of Observed and Predicted Values of Net Uplift Capacities of Piles (Das and Pise, 2003)

### *Conclusion from Above Investigation*

The stage of compressive loading is a significant parameter influencing the net uplift capacity of a pile. The net uplift capacity decreases with increase in the stage of compressive loading. At identical stage of loading and depth of embedment the rate of decrease of net uplift capacity is more in loose sand. The maximum decrease occurs at 100% stage of loading. The decrease in net uplift capacity may be due to the reduction in soil-pile friction angle,  $\delta$ , caused by the presence of compressive loading, which has been exhibited by the proposed logical approach. An assumption of a decrease in soil-pile friction angle, and using Chattopadhyay and Pise's method (1986) predicts uplift capacity of a pile, which is reasonably in agreement with the experimental value.

## **SUMMARY AND CONCLUDING REMARKS**

### *General*

Load-displacement response and uplift capacity under axial uplift load depends on length, diameter, surface characteristics of piles, method of installation, loading history and earth pressure coefficient  $K$  or uplift coefficient  $K_u$ .

### *Earth Pressure Coefficient*

Ireland (1957) suggests that average skin friction along the pile shaft is same for downward and uplift loading. Sowa (1957) and Downs and Chiurzzi (1966) indicate variation in skin friction indicating reduction for uplift load. Reduction of  $2/3$  for uplift load compared to compressive load. Begemann (1965) suggests reduction for average skin friction. Meyerhof and Adams (1968) recommends uplift coefficient between 0.7 to 1.0. Vesic (1970) finds skin friction same in tension and compression. Awad and Ayoub (1976) gives  $\mu = 0.33$  for cast in situ piles and 0.25 for other pile. Ismael and Klym (1979) recommends same value of uplift coefficient in tension and compression Kulhawy, Kozera and Withiam (1979) Finds  $K_s = K_a$  and  $K_s = (K_p)^{1/2}$ . Ismael and Al-Sanand (1986) finds  $K = 1.05$ .

### *Unit Skin Friction*

Unit skin friction along the depth of the pile varies approximately linearly up to a critical embedment depth and beyond it the skin friction remains roughly constant. The critical embedment depth is a function of relative density of sand and it lies between 10 - 30 times the diameter of pile (Das and Seeley, 1975; Chaudhuri and Symons, 1983; Das, 1983).

Chattopadhyay and Pise (1986) have also noted the presence of critical depth from their study. They found that it depends on length/diameter ratio,  $L/d$ ,  $\phi$  and  $\delta$ . It is more rational as it considers the shear and soil-pile friction angles and slenderness ratio.

### *Length and Diameter*

The depth of embedment has significant influence as it is directly related to the surface area of the pile. Longer piles are more resistant than shorter piles. As expected the larger diameter increases the surface area and so the resistance offered by them. Enlarged base piles have larger uplift capacity and it depends on the enlarged base diameter/shaft diameter ratio. Open-ended and closed-ended piles behave differently. The axial displacement associated with failure is also a function of the above parameters.

### *Pile Surface Characteristics*

The surface characteristics are reflected by the soil-pile friction angle. Therefore, the soil-pile friction angle  $\delta$  has significant influence on the behaviour of piles under uplift load. With increase in  $\delta$  value, the resistance increases i.e. rough piles offer more resistance. However, the analysis and investigation by Meyerhof and Adams (1968) conclude that for any value of  $\phi$  and  $\delta = 2/3\phi$ , the uplift coefficient  $K_u$  is relatively constant. Almost all the investigators found that soil-pile friction angle is a very important parameter. Similarly the adhesion coefficient between pile surface and cohesive soil has significant influence.

### *Shear Strength Parameters*

Shear strength parameters have significant influence on the pullout resistance of piles. The adhesion factor  $\alpha$  on which the uplift capacity of pile depends is influenced by the type of clay, its consistency, moisture content etc. along with the method of installation and type of loading. In general it is the function of untrained cohesion and it decreases with increase in strength and stabilises at higher values of cohesion from about 1.0 to 0.45 (Sowa, 1970). There are very limited studies available in cohesive soils.

The angle of shearing resistance  $\phi$  has significant influence. In general, higher the value of  $\phi$ ; more is the uplift resistance. Also  $\delta$  is inter-related to  $\phi$  for piles.

### *Relative Density $D_r$*

The unit weight of soil, angle of shearing resistance of soil and in turn



$\delta$  are functions of relative density. Higher the relative density of the soil, ultimate resistance is more.

### *Pile Groups*

Pile group response to uplift load depends on the configuration of the pile groups, spacing of piles, and number of piles in the group. The efficiency of the pile group increases with spacing. It decreases with increase in the size and number of piles in the group. The efficiencies reported for the groups are in the wide range of 50% to 180% (Meyerhof and Adams, 1968; Das, Seeley and Smith, 1976; Siddamal, 1989; Das and Azim, 1985; Madhav, 1987; Chattopadhyay, 1994; Mukherjee, 1996 and Patra, 2001). Analyses available to predict the ultimate resistance of groups by Meyerhof and Adams (1968) and Patra (2001) are too empirical and have limitations. They should be used with caution.

### *Additional Factors*

Method of installation of piles is a very important factor. The driven piles, their modes of driving influence the capacity (Vesic, 1970; McClelland, 1974; Awad and Ayoub, 1976; Levacher and Sieffert, 1984; Alawneh, Malkawi and Al-Deeky, 1999) These piles offer more resistance. The loading history, method of application of load from the top or bottom (Turner and Kulhawy, 1990; Joshi and Achari, 1992; Sharma and Soneja, 1987; Das and Pise, 2003) influence the behaviour.

The enlargement of the base of the pile significantly increases the resistance.

Pile head movement of roughly 5 to 15% of pile diameter is generally required to develop the ultimate resistance for straight shafted piles.

### *Methods of Analysis Available*

Methods are proposed by Meyerhof and Adams (1968), Das (1983), Kulhawy (1985) and Chattopadhyay and Pise (1986) to estimate the uplift capacity of single piles. The analysis proposed by Chattopadhyay and Pise (1986) appears to be more general for sandy soils. The design charts presented by them (1985) make it quite useful to the practicing engineers.

Methods are available to predict the uplift capacity of enlarged base piles by Meyerhof and Adams (1968), Sharma et al. (1978), Chandra Prakash (1980), Dickin and Leung (1990) and Sharma and Pise (1994). They are mostly empirical.

Analyses are also available by Meyerhof and Adams (1968), Madhav (1987) and Patra (2001) to predict the ultimate resistance and efficiency of pile groups.

### *Scope of Further Research*

The following broad areas of research have been identified to investigate the behaviour of pile foundations subjected to uplift loads:

1. Piles and pile groups under different conditions of loading.
2. Field-tests.
3. Effect of submergence.
4. Studies on instrumented piles for load transfer mechanism.
5. Analysis of pile groups and testing
6. Mechanism of failures including failure surfaces and modes of failure
7. Parametric study on the coefficient of earth pressure  $K$  and adhesion factor  $\alpha$
8. Effect of grain size distribution of soils and size effects of piles and pile groups
9. Effects of methods of installation
10. End conditions of piles

### **Acknowledgement**

The Indian Institute of Technology Kharagpur provides the ideal ambience for academic and research activities. I have been most fortunate in being one of the faculty members of the outstanding Institute. The author gratefully acknowledges the Books, Journals, and Proceedings of Conferences for their use in the preparation of the manuscript.

Much of the work reported in this paper is based on the thesis of the author and his students. The author wishes to thank his former students, Dr. M. Pal, Dr. B.C. Chattapadhyay, Dr. A.K. Khan, Dr. N.R. Patra, Mr. G. Nagaraju, A.K. Mandal, K. Sathyanarayana, U.V. Siddamal, B.V.R. Sharma and B.K. Dash. Dr. S. Mukherjee and Mr. S. Das also worked at IIT Kharagpur who were always in touch with the author for their research work. The students have been responsible for the fabrication and creation of testing facilities at "S.R. Sengupta Foundation Engineering Laboratory". Dr. N.R. Patra has been keenly involved in the preparation of the Lecture. A large number of faculty members of Civil Engineering Department and

students provided the author the necessary infrastructure, impetus and support at various stages for the preparation of this Lecture material and also the presentation material. The author is thankful to the AICTE, New Delhi for their offer of Emeritus Fellowship and financial support, and Government College of Engineering, Pune for making available their infrastructure.

## References

- ALAWNEH, A.S., MALKAWI, A.I.H., and AL-DEEKY, H. (1999) : "Tension Tests on Smooth and Rough Model Piles in Dry Sand", *Canadian Geotechnical Journal*, Vol.36, pp.746-753.
- AWAD, A. and AYOUB, A. (1976) : "Ultimate Uplift Capacity of Vertical and Inclined Piles in Cohesionless Soil", *Proc. 5th Conf. on SMFE*, Budapest, pp.221-227.
- BALLA, A. (1961) : "The Resistance to Breaking out of Mushroom Foundations for Pylons", *Proc. 5th Int. Conf. on SMFE*, Paris, Vol.1, pp.569-576.
- BEGEMANN, H.K.S. (1965) : "The Maximum Pulling Force on a Single Tension Pile Calculated on the Basis of Results of the Adhesion Jacket Cone", *Proc. 7th Int. Conf. on SMFE*, Paper No.1.
- CHANDRA PRAKASH (1980) : "Uplift Resistance of Under-reamed Piles in Silty Sand", *IGJ*, Vol.10, No.1, pp.46-59.
- CHATTOPADHYAY, B.C. (1986) : "A Study on Ultimate Resistance of Piles in Cohesionless Soil under Pulling Loads", *Ph.D. thesis*, IIT Kharagpur, India.
- CHATTOPADHYAY, B.C. (1994) : "Uplift Capacity of Pile Groups", *XIII ICMSFE*, New Delhi, India, pp.539-542.
- CHATTOPADHYAY, B.C. and PISE, P.J. (1984) : "Uplift Capacity of Vertical Piles in Dense Sand", *IGC-84*, Calcutta, India, pp.49-53.
- CHATTOPADHYAY, B.C. and PISE, P.J. (1985) : "Design Charts for Uplift Capacity of Piles in Sand", *Proc.IGC*, Roorkee, Vol.1, pp.243-248.
- CHATTOPADHYAY, B.C. and PISE, P.J. (1986) : "Uplift Capacity of Piles in Sand", *Journal of GTE Div.*, ASCE, Vol.112, No.9, pp.888-903.
- CHATTOPADHYAY, B.C. and PISE, P.J. (1987) : "Uplift Capacity of Driven Piles in Sand", *Journal of Institution of Engineers*, India, Vol.68, Part CI-2, UDC 624.154, pp.89-91.
- CHAUDHURI, K.P.R. and SYMONS, M.V. (1983) : "Uplift Resistance of Model Single Piles", *Proc. Conf. on GTE Practice in Offshore Engg.*, Austin, Texas, Sponsored by GTE Div., ASCE, pp.335-355.
- DAS, B.K. (2002) : "An Assessment of the Effects of Compressive Load and Installation on Uplift Capacity of Model Piles", *M.Tech. Dissertation*, IIT Kharagpur.
- DAS, B.M. (1983 ) : "A Procedure for Estimation of Uplift Capacity of Rough Piles", *Soils and Foundations*, Vol.23, No.3, pp.122-126

DAS, B.M. and AZIM, M.F. (1985) : "Uplift Capacity of Rigid Steel Pile Groups in Clay", *Soils and Foundations*, Vol.25, No.4, pp.117-122.

DAS, B.K. and PISE, P.J. (2003) : "Effect of Compressive Load on Uplift Capacity of Model Piles", *Journal of Geotechnical and Geoenvironmental Engg.*, ASCE., Paper No.023132, November.

DAS, B.M. and SEELEY, G.R. (1975) : "Uplift Capacity of Buried Model Piles in Sand", *Journal of GTE Div.*, ASCE, Vol.101, No.10, pp.1091-1094.

DAS, B.M. and SEELEY, G.R. (1981) : "Uplift Capacity of Pipe Piles in Saturated Clay", *Soils and Foundations*, Vol.21, No.4, pp.91-94.

DAS, B.M., SEELEY, G.R. and PFEIFLE, T.W., : "Pull-out Resistance of Rough Rigid Piles in Granular Soils", *Soils and Foundations*, Vol.17, No.3, pp.72-77.

DAS, B.M. and SEELEY, G.R. and SMITH, J.E. (1976) : "Uplift Capacity of Group Piles in Sand", *Journal of GTE Div.*, ASCE, Vol.102, No.3, pp.282-286..

DAS, S., MUKHERJEE, S. and VENKATNARAYANA, P. (1995) : "Pull-Out Resistance of Piles in Sand", *IGC-95*, Bangalore, India, Vol.1, pp.173-177.

DICKIN, E.A. and LEUNG, C.F. (1990) : "Performance of Piles with Enlarged Bases Subjected to Uplift Forces", *Canadian Geotechnical Journal*, Vol.27, No.5, pp.546-556.

DOWNS, D.I. and CHIEURZZI, R. (1966 ) : "Transmission Tower Foundations", *Journal of Power Div.*, ASCE, Vol.92, No.2, pp.91-114.

ISMAEL, N.F. and AL-SANAD, H.A. (1986) : "Uplift Capacity of Bored Piles in Calcareous Soils", *Journal of GTE Div.*, ASCE, Vol.112, No.10, pp.928-939

ISMAEL, N.F. and KLYM, T.W. (1979) : "Uplift and Bearing Capacity of Short Piers in Sand", *Journal of GTE Div.*, ASCE, Vol.105, No.5, pp.579-594.

IRELAND, H.O. (1957 ) : "Pulling Tests on Piles in Sand", *Proc. 4th Int. Conf. on SMFE*, London, Vol.2, pp.43-48.

ILAMPARUTHI, K. (1998 ) : "Behaviour of Pile Anchor Embedded in Sand", *IGC-1998*, New Delhi, India, Vol.2, pp.85-88.

JOSHI, R.C., ACHARI, G. and KANIRAJ, S.R. (1992) : "Effect of Loading History on the Compression and Uplift Capacity of Driven Model Piles in Sand", *Canadian Geotechnical Journal*, Vol.29, pp.334-341.

KISHIDA, H. (1967) : "Ultimate Bearing Capacity of Piles Driven into Loose Sand", *Soils and Foundations*, Vol.7, No.3, pp.20-29.

KULHAWY, F.H., KOZERA, D.W. and WITHIUM, J.L. (1979 ) : "Uplift Testing of Model Drilled shafts in Sand", *Journal of GTE Div.*, ASCE, Vol.105, No.1, pp.31-47.

KULHAWY, F.H. (1985) : "Drained Uplift Capacity of Drilled Shafts", *11th Int. Conf. on SMFE*, San Francisco, Vol.3, pp.1549-1551.

LEVACHER, D.R. and SIEFFERT, J. (1984) : "Tests on Model Tension Piles", *Journal of GTE Div.*, ASCE, Vol.110, No.12, pp.1735-1747.

MADHAV, M.R. (1987) : "Efficiency of Pile Groups in Tension", *Canadian Geotechnical Journal*, Vol.24, pp.149-153.

- McCLELLAND, B. (1974) : (Design of Deep Penetration Piles for Ocean Structures", *Journal of GTE Div.*, ASCE, Vol.100, No.7, pp.709-745.
- MEYERHOF, G.G. (1973) : "Uplift Resistance of Inclined Anchors and Piles", *Proc. 8th Int. Conf. on SMFE*, Moscow, Vol.2.1, pp.167-173.
- MEYERHOF, G.G. and ADAMS, J.I. (1968) : "The Ultimate Uplift Capacity of Foundations", *Canadian Geotechnical Journal*, Vol.5, No.4, pp.64-70.
- MUKHERJEE, S., VENKATNARAYANA, P. and DAS, S. (1994) : "A Study on Behaviour of Pile Groups in Sand Under Uplift", *IGC-94*, pp.129-131.
- MUKHERJEE, S. (1996) : "Pullout Behaviour of Pile Groups in Sand", *Ph.D. thesis*, I.I.T. Kharagpur, India.
- NAGARAJU, G. and PISE, P.J. (1995) : "Behaviour of Piles Under Inclined Pulling Loads in Layered Sand", *IGC-95*, Bangalore, India, Vol.1, pp.187-190.
- O'NEILL, M.W., HAWKINS, R.A. and MAHAR, L.J. (1982) : "Load Transfer Mechanisms in Piles and Pile Groups", *Journal of GTE Div.*, ASCE, Vol.108, No.12, pp.1605-1623.
- PATRA, N.R. (2001) : "Ultimate Resistance of Pile Groups in Sand under Oblique Pulling Loads", *Ph.D. thesis*, IIT Kharagpur, India.
- PATRA, N.R. and PISE, P.J., (1999) : "Behaviour of Pile Groups Under Oblique Pulling Loads", *4th International Conference on Deep Foundation Practice*, Singapore, pp.359- 366.
- PISE, P.J. and PATRA, N.R. (2000) : "Uplift Resistance of Piles and Pile Groups - A Review", *Invited Contribution to Golden Jubilee Publications of the Department of Civil Engineering*, Indian Institute of Science, Bangalore - 'Research Perspectives in Civil Engineering', Under process..
- PATRA, N.R. and PISE, P.J. (2001) : "Ultimate Lateral Resistance of Pile Groups in Sand", *Journal of Geotechnical and Geoenvironmental Engg. Div.*, ASCE, Vol.127, No.6, pp.481-487
- PISE, P.J. (1996) : "Design Aspects of Uplift Capacity of Piles", *Seminar on Piles*, IGS-Delhi Chapter, pp.31-38
- POOROOSHASB, H.B. and PARAMESWARAN, V.R. (1982 ) : "Uplift of Rigid Piles in Frozen Sand", *Soils and Foundations*, Vol.22, No.2, pp.82-88.
- POULOS, H.G. and DAVIS, E.H. (1980) : *Pile Foundation Analysis and Design*, John Wiley & Sons, New York, 1st Ed.
- RAMESH BABU (1998) : "Uplift Capacity and Behaviour of Shallow Horizontal Anchors in Soil", *Ph.D. Thesis*, I.I.Sc. Bangalore, India.
- RUFFIER and MAHLER (1989) : "Finite Element Analysis of Plates and Foundations", *Proc. 12th Int. Conf. on SMFE*, pp.1209-1212.
- SATHYANARAYANA, K. (2000) : "Uplift Capacity of Anchor Piles in Layered Sandy Soil", *M.Tech. Thesis*, IIT, Kharagpur, India.
- SIDDAMAL, U.V. (1989) : "Behaviour of Pile Groups under Uplift Loads", *M.Tech. Thesis*, IIT, Kharagpur, India.

- SHARMA, B.V.R. (1988) : "Uplift Capacity of Anchor Piles in sand Under Axial-Pulling Loads", *M.Tech Thesis*, I.I.T. Kharagpur, India.
- SHARMA, D., JAIN, M.P. and CHANDRA PRAKASH, C. (1978) : *Hand Book of Under-reamed and Bored Compaction Piles*, CBRI, Roorkee, India.
- SHARMA, D. and SONEJA, M.R. (1987) : "A Field Study of the Conditions of Pull and Skin Friction of Piles", *IGC-87*, Bangalore, India, Vol.1, pp.147-150.
- SHARMA, B.V.R. and PISE, P.J. (1994) : "Uplift Capacity of Anchor Piles in Sand Under Axial-Pulling Loads", *IGJ*, Vol.24, No.3, pp.181-203.
- SOWA, V.A. (1970) : "Pulling Capacity of Concrete Cast-In-Situ Bored Piles", *Canadian Geotechnical Journal*, Vol.7, pp.482-493.
- SUBBA RAO, K.S. and VENKATESH, K.H. (1985) : "Uplift Behaviour of Short Piles in Uniform Sand", *Soils and Foundations*, Vol.25, No.4, pp.01-07.
- SULAIMAN, I.H. and COYLE, H.M. (1976) : "Uplift Resistance of Piles in Sand", *Journal of GTE Div.*, ASCE, Vol.102, No.5, pp.559-562.
- TRAN-VO-NHIEM (1971) : "Ultimate Uplift Capacity of Anchor Piles", *4th Conf. on SMFE*, Budapest, pp.829-836.
- VESIC, A.S. (1970) : "Tests on Instrumented Piles, Ogeechee River Site", *Journal of SMFE Div.*, ASCE, Vol.96, No.2, pp.561-583.
- VESIC, A.S. (1971) : "Breakout Resistance of Objects Embedded in Ocean Bottom", *Journal of SMFE Div.*, ASCE, Vol.97, No.9, pp.1183-1205.
- TURNER, E.A. (1962) : "Uplift Resistance of Transmission Tower Footings", *Journal of Power Div.*, ASCE, Vol.88, pp.17-33.
- TURNER, J.P. and KULHAWY, F.H. (1990) : "Drained Uplift Capacity of Drilled Shafts Under Repeated Loading", *Journal of GTE Division.*, Vol.116, No.3, pp.470-491.

## Notations

- $c_a$  = average adhesion along pile shaft
- $W_p$  = Weight of pile
- $A_s$  = surface area of the embedded pile
- $K_s$  = coefficient of earth pressure
- $p_{av}$  = average skin friction
- =  $(1/2 K_s \tan \delta \gamma L)$
- $\delta$  = pile friction angle
- $\gamma$  = effective unit weight of soil
- $d_b$  = diameter of the base
- $d$  = diameter of pile shaft

- $K_u$  = nominal uplift coefficient of earth pressure on vertical plane through footing edge  
 $f_s$  = average unit skin friction of soil on shaft  
 $N_c, N_q$  = bearing capacity factors as for downward loading.  
 $c$  = unit cohesion  
 $s$  = shape factor governing the passive earth pressure on a convex cylindrical wall  
 $W_f$  = weight of soil and pile in cylinder above base  
 $f_s$  = ultimate shaft shear resistance  
 $\sigma'_{vb}$  = effective vertical stress at level of pile base  
 $Q_u$  or  $P_u$  = ultimate uplift capacity/resistance of a single pile  
 $Q_{un}$  or  $P_{un}$  = net uplift resistance/capacity of a single pile  
 $L$  = length of embedment  
 $p$  = perimeter of pile  
 $L_{cr}$  = critical depth  
 $D_r$  = relative density of sand  
 $A_1$  = net uplift capacity factor for piles.  
 $N_q$  = breakout factor for horizontal anchor plates  
 $A$  = annular area of the base enlargement  
 $= \pi/4(B^2 - d^2)$   
 $d_1$  = depth of centre of the first under-reamed bulb  
 $d_n$  = depth of the centre of the last under-reamed bulb  
 $n$  = number of under-reamed bulbs  
 $A$  = gross uplift capacity factor  
 $Q_{ug}$  = gross uplift capacity of a group  
 $\eta$  = efficiency of a pile group